



Technical Note

Project Number: T17556

Project: Graveley Village

Title: Traffic Impact Assessment

Date: 10th November 2017

Prepared By: Lianne Brook

Distribution List: Jack Rigg

1.1 Introduction

1.1.1 This technical note has been prepared by PTB on behalf of Graveley Parish Council to provide an assessment of the local highway network through Graveley Village and provide commentary on the likely traffic impact resulting from the North Herts and Stevenage Local Plans.

1.1.2 This report is intended to provide a review of the allocation sites with consideration to the impact these may have on Graveley Village. This report will also consider any strategic highway improvement schemes and provide commentary on how these may impact on the village.

1.1.3 Following this introduction, this note is set out as follows:

- Section 1.2 – Highway Network and Existing Conditions;
- Section 1.3 – Assessment Methodology;
- Section 1.4 – Future year Capacity Assessment;
- Section 1.5 – Review of the Allocation Sites;
- Section 1.6 – Review of Existing Modelling Reports and Proposals;
- Section 1.7 – Commentary on Highway Improvement Schemes; and,
- Section 1.8 – Summary and Conclusions.

1.1.4 This note has been undertaken at the request of Graveley Parish Council, thus should not be entrusted to any third party without written permission from PTB Transport Planning Ltd. However, should any information contained within this report be used by any unauthorised third party, it is done so entirely at their own risk and shall not be the responsibility of PTB Transport Planning Ltd.



Technical Note

1.1.5 This report has been compiled using data from a number of external sources (such as mapping and traffic count data); these sources are considered to be trustworthy and therefore the data provided is considered to be accurate and relevant at the time of preparing this report.

1.2 Highway Network and Baseline Conditions

1.2.1 Graveley Village is located within the North Herts District, approximately two miles to the north of Stevenage.

1.2.2 The B197, High Street is the main route through the village and connects with the A1 to the south via a grade separated roundabout with Graveley Road, A602 and Stevenage Road (Junction 8). In the north, High Street connects with Graveley Lane which provides a connection west to Hitchin, and to Junction 9 of the A1 via the A505.

1.2.3 A site visit was undertaken to observe the current traffic conditions. It was noted that there was a large volume of vehicles travelling south through the village and there was some delay for right turning vehicles exiting Church Lane and Oak Lane.

1.2.4 During the morning peak period, Junction 8 of the A1 was observed to be operating with severe delays. It was noted that the circulatory traffic was blocking the exit arms, demonstrating that the junction had reached saturation. Stationary queues over approximately 1.75 kilometres were observed along the A602 eastbound between Hitchin and Stevenage.

1.2.5 A Manual Classified Count (MCC), including queue surveys, was undertaken at the Oak Lane and Church Lane priority junctions within the village centre to establish the baseline traffic flows.

1.2.6 The surveys were undertaken on Thursday 19th of October 2017 during the morning and evening peak periods (07:00 – 10:00 and 16:00 – 19:00). The surveyed morning peak hour was between 07:45 and 08:45 whilst the evening peak was between 17:00 and 18:00. Flow diagrams showing the surveyed turning counts during the morning and evening peak period can be found in **Figures 2.1** and **2.2** whilst the full survey data can be found at **Appendix A**.

1.2.7 The surveys show a significant southbound flow through the village during the morning peak period. These flows are double the AM northbound flow and do not appear to be reciprocated in the PM peak period, i.e. with a significant northbound return flow.

1.2.8 In order to establish if this was representative and not a result of an abnormal highway occurrence, a validation check was undertaken at the time of the site visit by way of a 15 minute count; c.300 southbound vehicles were counted in a 15 minute period and as such confirmed that the surveyed flows are a reasonable and representative account of the flows through Graveley.



Technical Note

1.2.9 As such, this suggests that a large number of vehicles are routing through the village to avoid the aforementioned A1 junction.

1.2.10 In order to determine the likely capacity constraints on the local highway network in Graveley, a formal capacity assessment has been undertaken using industry standard software at the staggered crossroad junction of High Street/Church Lane/Oak Lane.

1.2.11 The full output files for the staggered crossroad junction, showing the geometry and capacity calculations, are shown in **Appendix B** whilst Table 1 summarises the results.

Table 1 – 2017 Baseline Capacity Assessment

Approach	AM Peak 07:45 – 08:45			PM Peak 17:00 – 18:00		
	RFC	Queue	Delay (s)	RFC	Queue	Delay (s)
Church Lane	0.75	3	89	0.08	0	10
High Street SB	0.04	0	6	0.02	0	6
Oak Lane LT	0.06	0	8	0.02	0	8
Oak Lane RT	0.15	0	23	0.05	0	13
High Street NB	0.02	0	11	0.04	0	7

1.2.12 Table 1 demonstrates that Church Lane is operating close to capacity during the morning peak period with delays approaching 2 minutes.

1.2.13 The average modelled queue lengths are consistent with the surveyed queues and as such it is considered that the model is representative. Whilst there was an average queue of three cars across the peak hour on Church Lane, it was noted that the queue reached a maximum of 14 vehicles. A summary of the surveyed queue lengths is provided at Table 2.



Technical Note

Table 2 – Surveyed Queue Lengths

AM Peak 07:45 – 08:45				
Time	High Street N	Church Lane	High Street S	Oak Lane
07:45	0	3	0	1
07:50	0	2	0	0
07:55	0	1	0	0
08:00	0	2	0	0
08:05	0	5	0	0
08:10	0	0	0	1
08:15	0	14	0	0
08:20	0	7	0	2
08:25	0	4	0	0
08:30	0	0	0	0
08:35	0	1	0	0
08:40	0	0	0	0
PM Peak 17:00 – 18:00				
17:00	0	0	0	0
17:05	0	0	0	0
17:10	0	0	0	2
17:15	0	0	0	0
17:20	0	0	0	0
17:25	0	0	9*	0
17:30	0	0	0	0
17:35	0	0	0	0
17:40	0	0	0	0
17:45	0	0	0	0
17:50	0	0	0	0
17:55	0	0	0	0

1.3 Assessment Methodology

1.3.1 In order to assess the likely impact that the Local Plan Allocations may have on the village of Graveley, two future year capacity assessments have been undertaken.

1.3.2 The first assessment has been based on a TEMPro growth factor which considers the likely increase in vehicle movements across the whole network to the end of plan period. It does not provide any detailed assumptions on how vehicle movements from any individual sites may assign at local junctions or links.

1.3.3 The second assessment does not apply any background growth to the network but rather it incorporates the likely traffic generation and assignment of the specific allocation sites through Graveley village. It therefore assumes that the only growth will be that associated with Local Plan Allocations.



Technical Note

1.4 Future Year Capacity Assessment

1.4.1 In order to run junction capacity assessments for an 'end of plan' future year scenario, traffic growth rates for the local highway network have been obtained from TEMPro for the area of North Hertfordshire and for a period of 14 years. The traffic growth rates are set out below:

- 2017 – 2031 Weekday AM Peak – 1.1988
- 2017 – 2031 Weekday PM Peak – 1.2034

1.4.2 The NTM adjusted TEMPro factors presented above have been applied to the baseline surveyed traffic flows and used to calculate the 2031 traffic flows on the local highway network. The 2031 baseline traffic movements for the weekday morning and evening peaks are presented in **Figures 4.1** and **4.2**.

1.4.3 It is important to note that this would not include the impact associated with traffic growth of any windfall sites (i.e. those not already formally allocated).

1.4.4 The formal capacity assessment has been updated for the future year traffic scenarios and can be seen at Table 3.

Table 3 – 2031 Capacity Assessment

Approach	AM Peak 07:45 – 08:45			PM Peak 17:00 – 08:00		
	RFC	Queue	Delay (s)	RFC	Queue	Delay (s)
Church Lane	2.09	37	1661	0.11	0	11
High Street SB	0.05	0	6	0.03	0	7
Oak Lane LT	0.08	0	9	0.03	0	9
Oak Lane RT	0.27	0	41	0.07	0	15
High Street NB	0.03	0	14	0.05	0	7

1.4.5 Table 3 demonstrates that the junction will operate significantly over capacity for the 2031 scenario using NTM adjusted growth forecasts from TEMPro.

1.5 Allocation Sites

1.5.1 A review of the North Herts District and Stevenage Local Plans has been undertaken to establish the potential impact of the proposed site allocations on the village of Graveley.

1.5.2 The sites that have been included within the assessment are detailed below. A generic trip rate has been assumed to determine the likely level of vehicle movements that may be associated with each of the proposed developments. The TRICs output files can be seen at **Appendix C** and a summary of the trip rate can be seen at Table 4.



Technical Note

Table 4 – Trip Rates

	Residential Trip Rate		B1 Office Trip Rate		B8 Warehousing (Commercial) Trip Rate	
	IN	OUT	IN	OUT	IN	OUT
AM	0.148	0.392	1.42	0.133	0.452	0.152
PM	0.327	0.163	0.108	1.262	0.076	0.409

NB: AM peak is 08:00-09:00 and PM peak is 17:00-18:00; trips have been rounded.

1.5.3 In addition to this, 2011 Journey to Work census data has been reviewed in order to ascertain the likely distribution of vehicle trips, the data is provided at **Appendix D**.

Land North of Stevenage

1.5.4 There is a draft allocation for approximately 1,700 dwellings, located to the north of Stevenage. 900 of which are covered within policy NS1 of the NHDC Draft Local Plan and 800 within policy H03 of the Stevenage Draft Local Plan. It is stated that access will be taken from North Road and a signalised junction is proposed at the junction with Graveley Road.

1.5.5 A proposed development of 1,700 dwellings is likely to generate approximately 918 two way trips in the morning peak period and 833 two way trips during the evening peak period. A review of the census data indicates that 11% of trips are likely to travel to/from the north via High Street and Graveley village.

Land at Roundwood

1.5.6 A draft allocation for 330 dwellings is proposed within the NHDC Local Plan to the west of Roundwood (Policy GA1) and it is stated that access is proposed from the existing residential streets.

1.5.7 A proposed development of 330 dwellings is likely to generate approximately 178 two way trips in the morning peak period and 162 two way trips during the evening peak period. A review of the census data indicates that 12% of trips are likely to travel to/from the A1 junction via Back Lane; and 6% north via High Street and Graveley village.

1.5.8 As per PTB's previous work, it is considered that the Transport Assessment for this development site has underestimated the number of vehicles assigned to Back Lane.

Land North East of Ashby

1.5.9 A draft allocation for 600 dwellings is proposed within the NHDC Local Plan to the north east of Ashby (Policy GA2) and it is stated that access is proposed from Mendip Way.



Technical Note

1.5.10 A proposed development of 600 dwellings is likely to generate approximately 324 two way trips in the morning peak period and 294 two way trips during the evening peak period. A review of the census data indicates that 12% of trips are likely to travel to/from the A1 junction via Back Lane; and 6% north via High Street and Graveley village.

Land West of North Road

1.5.11 A employment development of c.20,000sqm of B1 use is proposed within the draft Stevenage Local Plan on land to the west of North Road (Policy EC1/4). It is assumed that access will be from from North Road

1.5.12 A proposed development of 20,000sqm B1 office space is likely to generate approximately 311 two way trips in the morning peak period and 274 two way trips during the evening peak period. A review of the census data indicates that 26% of trips are likely to travel to/from the north via High Street and Graveley village.

Land West of Junction 8

1.5.13 A employment development of c.12,500 of B8 use is proposed within the draft Stevenage Local Plan on land to the west of the A1 junction (Policy EC1/7). It is stated that access is proposed from Stevenage Road.

1.5.14 A proposed development of c12,500 B8 warehousing (commercial) is likely to generate approximately 76 two way trips in the morning peak period and 61 two way trips during the evening peak period. A review of the census data indicates that 12% of trips are likely to travel to/from the north via High Street and Graveley village.

1.5.15 The vehicle movements associated with the proposed allocations as outlined above have been added to the surveyed 2017 baseline scenario. These flows can be seen in **Figures 5.1** and **5.2** and have been modelled using the junctions 9 software in order to ascertain the likely direct cumulative impact of all the individual sites. The results can be seen at Table 5.

Table 5 – Allocation Capacity Assessment

Approach	AM Peak 07:45 – 08:45			PM Peak 17:00 – 18:00		
	RFC	Queue	Delay (s)	RFC	Queue	Delay (s)
Church Lane	1.62	40	739	0.17	0	12
High Street SB	0.04	0	6	0.02	0	7
Oak Lane LT	0.06	0	9	0.03	0	9
Oak Lane RT	0.21	0	34	0.06	0	15
High Street NB	0.09	0	11	0.12	0	7

1.5.16 Table 5 demonstrates that the junction will operate significantly over capacity for the local plan future year scenario using the calculated direct flows from the draft allocations.



Technical Note

1.6 Review of Other Modelling Reports

1.6.1 A review has been undertaken of the existing modelling reports produced by NHDC and HCC to date. Most notably, AECOM undertook an assessment of the local highway network and the impact that the preferred Local Plan scenario may have. The assessment used the Welwyn & Hatfield and Stevenage and Hitchin Saturn Model (WHsSH).

1.6.2 The report highlighted delays across the network for the future 2031 scenario, including delays at junction 8 of the A1 and at the priority junction of Graveley Road and North Road. The report identified 11 specific highway schemes to mitigate against the impact of the local plan.

1.6.3 The NHDC Proposed Submission Local Plan acknowledges that these improvements alone will not be sufficient enough to mitigate against the proposed development and states:

“The scale of growth within the District will result in a significant number of new trips on a transport network that is already under stress in certain areas. Congestion issues are particularly focused within Hitchin and junctions relating to the A1(M). Not only as a result of growth in North Hertfordshire, but also in relation to existing issues and development in nearby authorities. There is a clear need to focus on promoting sustainable travel modes to limit the impacts of growth whilst delivering significant physical mitigation measures. Our transport modelling has helped to identify 11 specific schemes that will be required in the District over the period to 2031 as well as other schemes in neighbouring Stevenage which are influenced by this Plan’s proposals”.

1.6.4 It is considered that whilst there are various strategic highway assessments that have been prepared, there has been no detailed consideration given to the impact on Graveley village. It is noted that the NHDC Transport Strategy (October 2017) acknowledges the impact from through traffic and states:

“Great Wymondley/Graveley are both villages which can be affected by through traffic using more local roads to bypass congestion on e.g. the A1(M). Measures here will need to be appropriate to the ‘environmental capacity’ of the villages, and not increase through traffic.”

1.7 Highway Improvement Schemes

1.7.1 It is acknowledged that since the issue of the AECOM report (October 2017), it has been proposed that the priority junction of North Road/Graveley Road is upgraded to provide a signalised junction. Whilst the LinSig model of this junction is not available, it is likely that the scheme provided will provide sufficient capacity for the draft residential and commercial allocations proposed to the north of Stevenage. However, it is unlikely that this mitigation measure will bring any benefits to the village of Graveley.



Technical Note

1.7.2 The improvement scheme included within the AECOM report for the A1 between junctions 7 and 8 comprises:

- A1(M) J8 SB Offslip
 - Northern approach increased to 3 lanes
 - Signals Optimised
- A1(M) J8 Hitchin Rd NB approach
 - Signals Optimised
 - Eastern approach increased number of lanes to 3
- A1(M) J8 NB Offslip
 - Signals Optimised
 - Southern approach lanes increased to 3
 - Segregated Left Filter with 2 lanes at signal junction
- A1(M) J8 A602 EB approach
 - Signals Optimised
- A1(M) Widening junction 7 – 8
 - Widening of A1(M) in both direction to 3 lanes (See HM17)

1.7.3 As previously stated, it is anticipated that a large number of vehicles routing southbound through Graveley are doing so to avoid delays at junction 8 of the A1. Whilst it is evident within the AECOM modelling report that this improvement will bring a noticeable reduction to the vehicles through Graveley village, it does not state a quantity.

1.7.4 As such, a capacity assessment has been run with varying levels of reduction to the southbound traffic to determine the level of rerouting the highway improvements would need to achieve in order to provide a significant benefit to the operation of the highway network within the village of Graveley (this assessment includes the calculated vehicle movements associated with the draft allocations).

1.7.5 This exercise indicated that a 30% reduction of southbound movements (c.380 vehicles) is required from a combination of the highway improvement scheme and the promotion of sustainable travel in order to provide a scenario in at which the staggered crossroad would operate with reasonable level of queuing and delays. The junction modelling results can be seen at Table 6.



Technical Note

Table 6 – Allocation Capacity Assessment with Improvements

Approach	AM Peak 07:45 – 08:45			PM Peak 17:00 – 18:00		
	RFC	Queue	Delay (s)	RFC	Queue	Delay (s)
Church Lane	0.81	4	73	0.15	0	10
High Street SB	0.04	0	6	0.02	0	7
Oak Lane LT	0.06	0	8	0.03	0	9
Oak Lane RT	0.14	0	22	0.06	0	14
High Street NB	0.07	0	9	0.11	0	7

1.7.6 Table 6 demonstrates that a 30% reduction in through traffic will reduce queues and delays significantly, with the junction likely operating at a similar level to the 2017 baseline.

1.7.7 The junction has been tested to establish the likely impact of the proposed allocations, should the A1 improvement scheme bring just a 10% reduction in southbound movements. The results for the AM peak period can be seen at Table 7 below.

Table 7 – Capacity Assessment – 10 % reduction to SB flows

Approach	AM Peak 07:45 – 08:45		
	RFC	Queue	Delay (s)
Church Lane	1.20	20	370
High Street SB	0.00	0	6
Oak Lane LT	0.06	0	9
Oak Lane RT	0.18	0	29
High Street NB	0.08	0	10

1.7.8 Table 7 indicates that with a 10% reduction, the junction will likely operate above capacity for the morning peak period, with an average queue of 20 and a delay of approximately 6 minutes on Church Lane.

1.7.9 This capacity assessment demonstrates how critical the A1 improvement scheme is to the impact of the allocations on Graveley.

1.8 Summary and Conclusions

1.8.1 This technical note has been prepared by PTB on behalf of Graveley Parish Council to provide an assessment of the local highway network through Graveley Village and provide commentary on the likely impact as a result of the North Herts and Stevenage Local Plan.

1.8.2 It is noted that there has been significant assessment of the allocations on a strategic level however there is little consideration to the direct impact on the operation of junctions within Graveley village.

1.8.3 This assessment has demonstrated that a combination of the highway improvements schemes and the promotion of travel by more sustainable means



Technical Note

would need to result in a reduction in 30% of southbound movements to mitigate against the impact of the proposed allocation sites within Graveley.

1.8.4 The junction of Church Lane with High Street is particularly sensitive to additional traffic and, as such, our view is that detailed consideration and analysis of this junction should have been carried out as part of the Local Plan assessments.

1.8.5 It is clear from the analysis undertaken in this report that if the proposed highway infrastructure and sustainable measures do not significantly reduce the through-traffic within Graveley then mitigation will be required.

1.8.6 Our view is that if the local plan sites come forward without appropriate mitigation in Graveley, the cumulative impact of these sites would be 'severe' and thus the local plan proposals would fail the test in paragraph 32 of the NPPF.



Technical Note

FIGURES

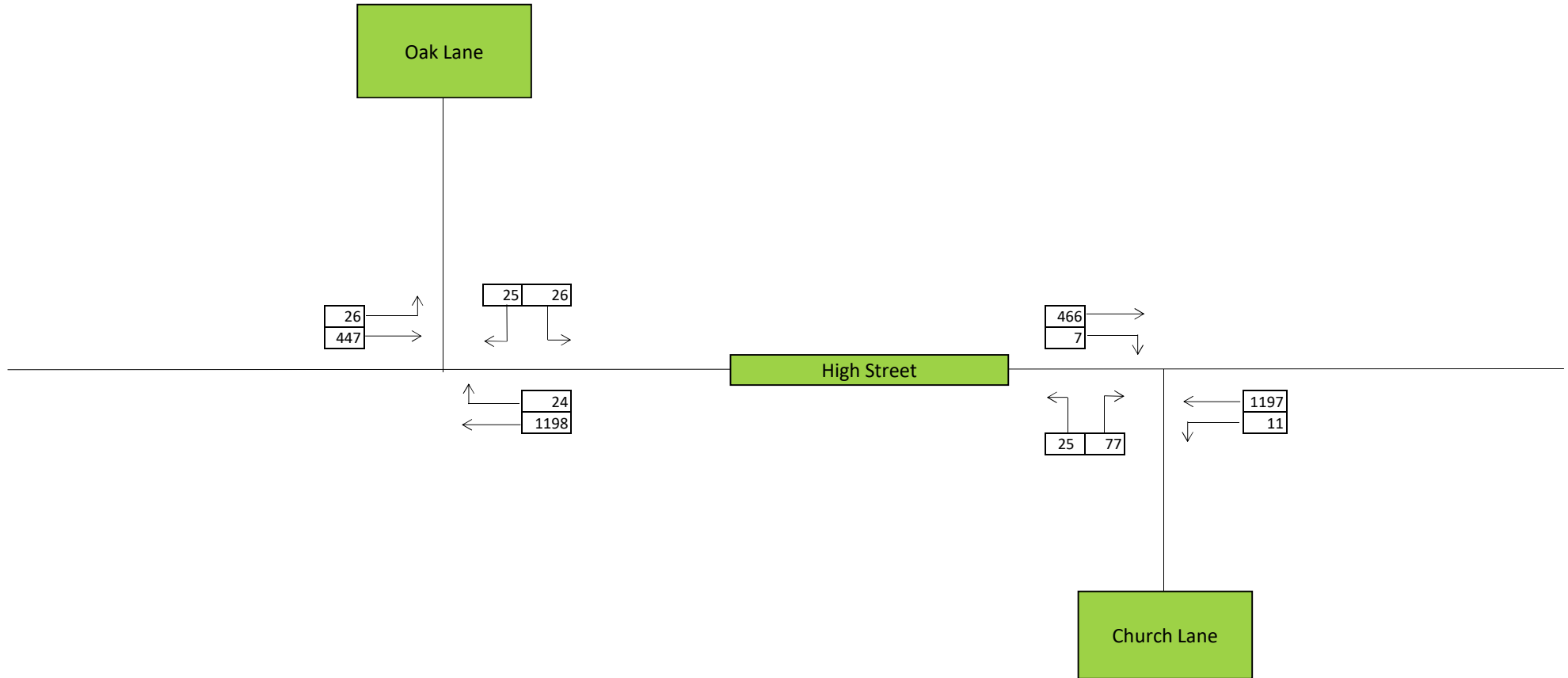

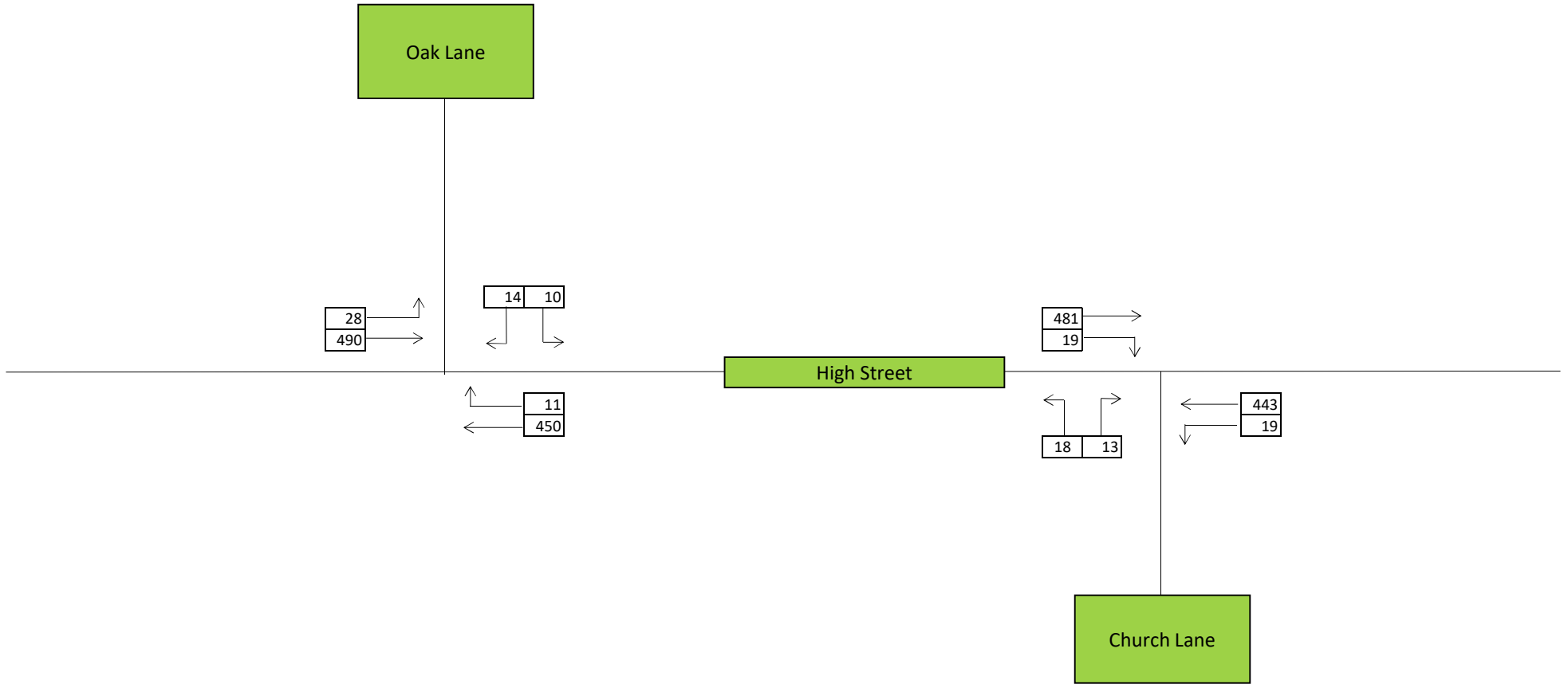

	T17556 Graveley
	Figure 2.1 Surveyed Baseline 07:45 - 08:45

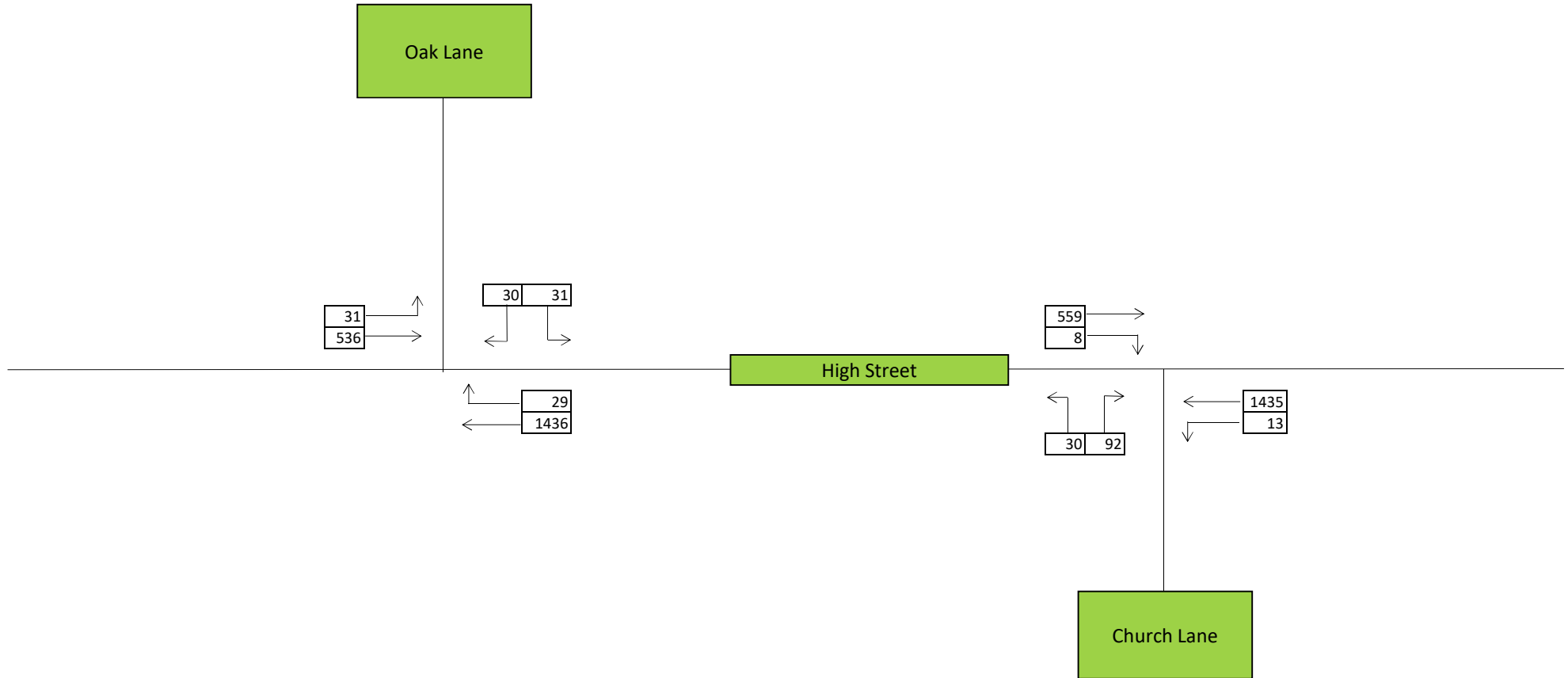

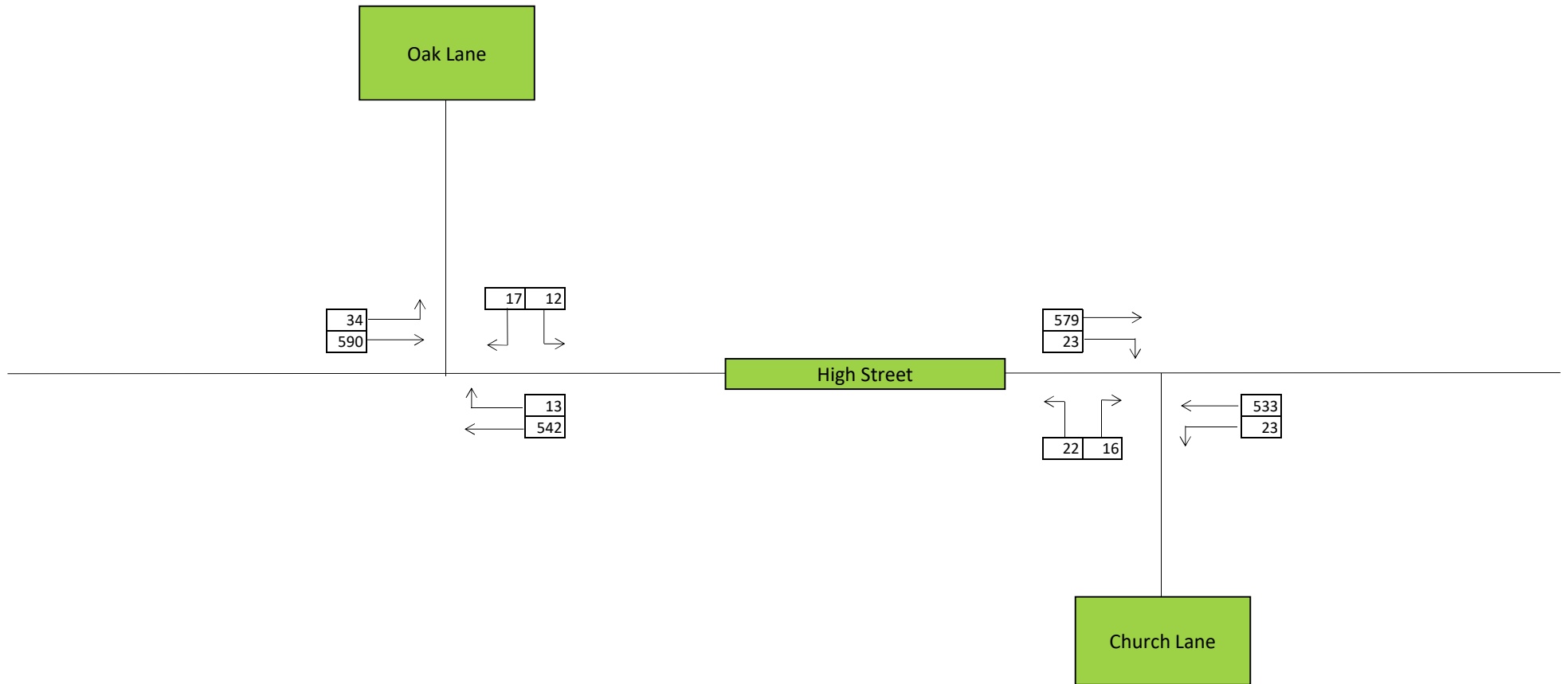

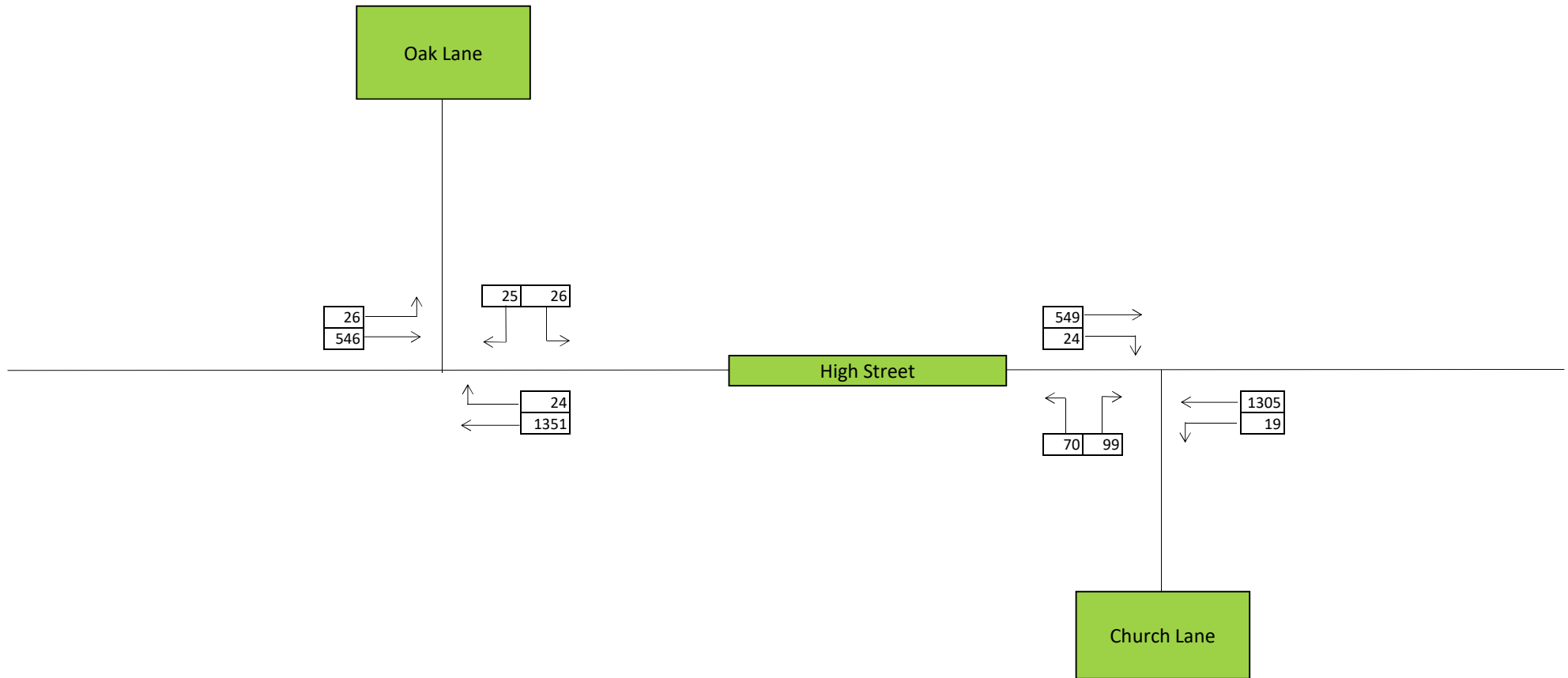



	T17556
	Graveley
Figure 5.1	
2017 + Allocations	
07:45 - 08:45	

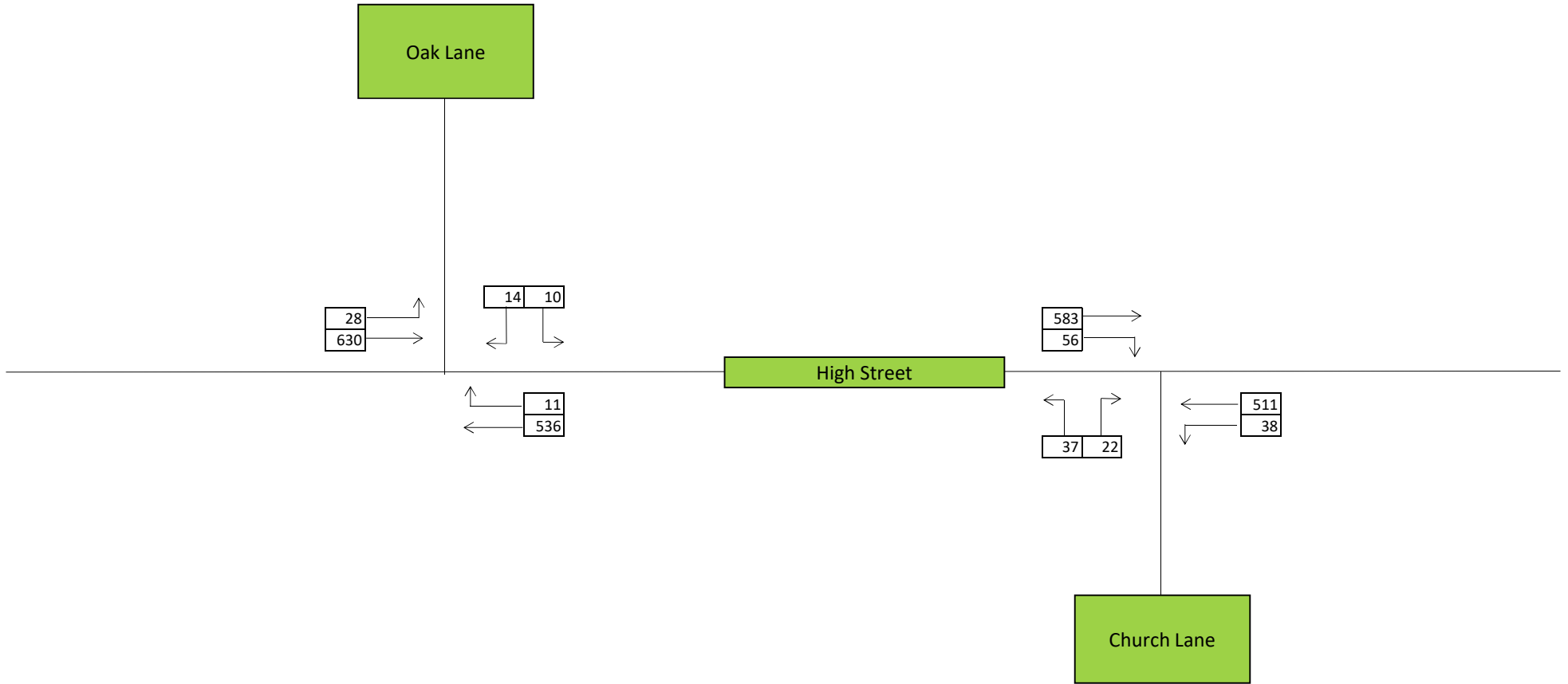



Technical Note

APPENDIX A - SURVEYED TURNING COUNTS

For and on behalf of:



GRAVELEY

Thursday 19 October 2017

0700-1000
1600-1900

Drawing N^o: 22229 - 01

Site: 1

Location: High Street /
Oak Lane

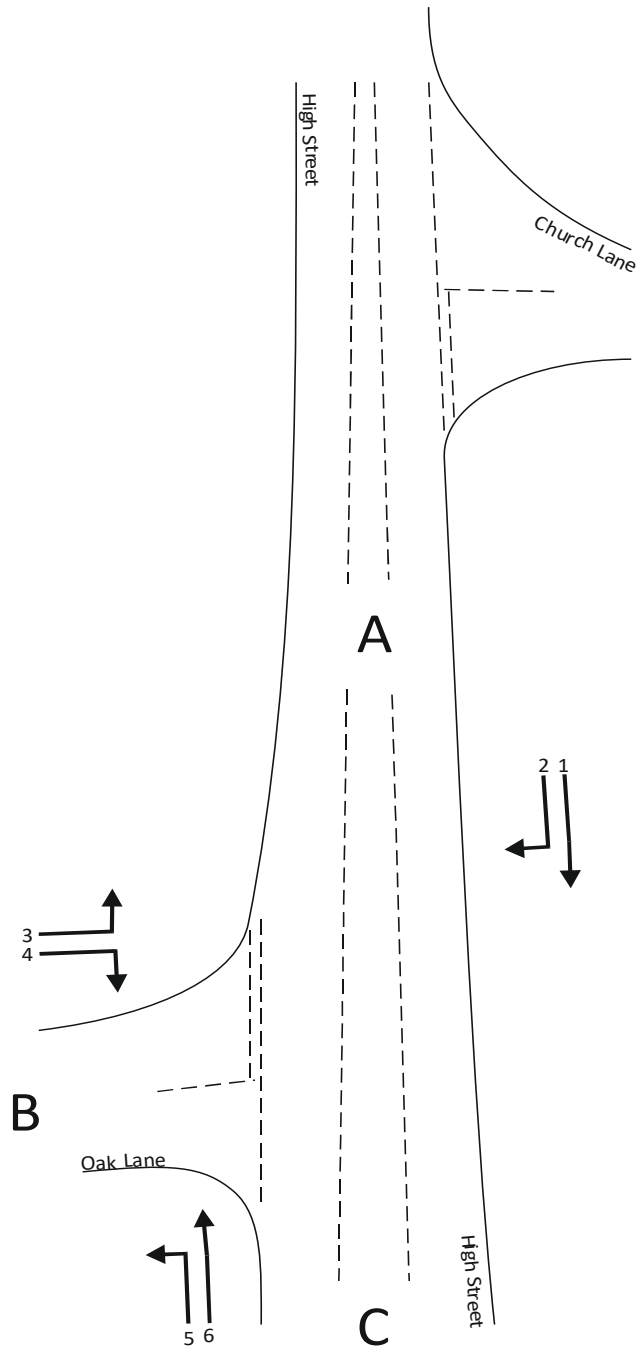

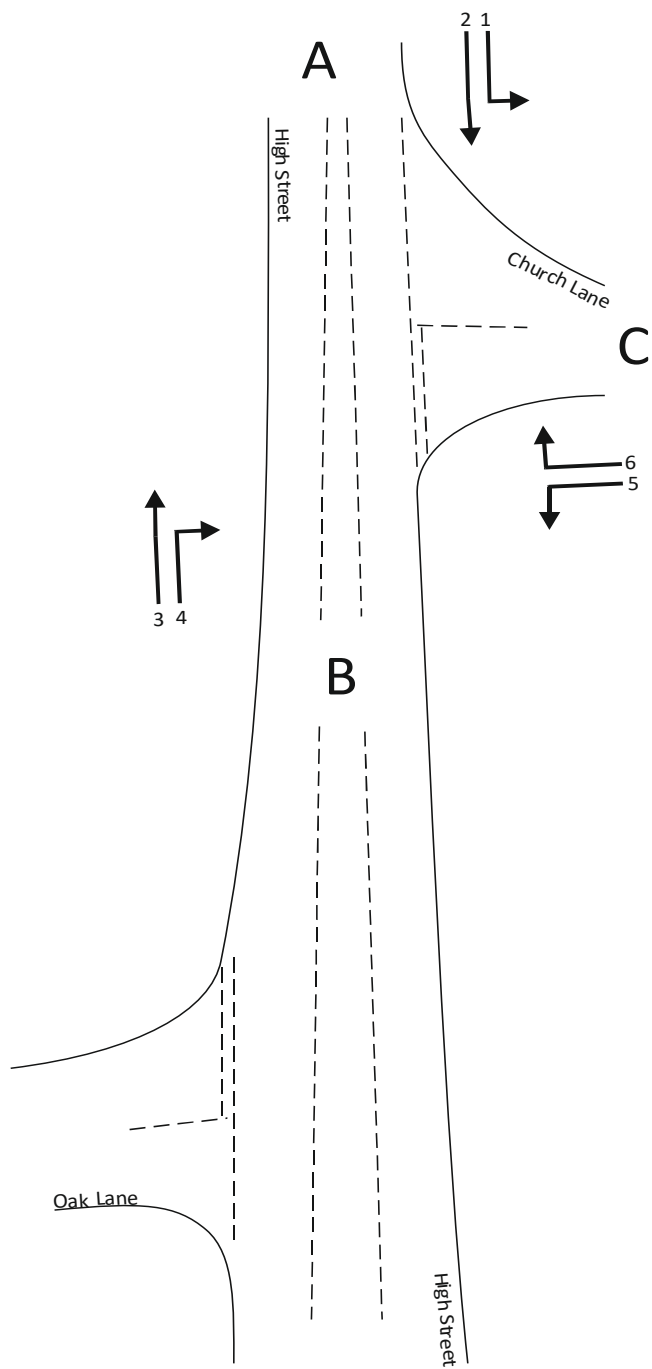

GRAVELEY
 Thursday 19 October 2017
 0700-1000
 1600-1900

Drawing N°: 22229 - 02
 Site: 2
 Location: High Street / Church Lane

MANUAL CLASSIFIED COUNTS



JOB REF: 22229

JOB NAME: GRAVELEY

SITE: 1

LOCATION: HIGH STREET / OAK LANE

DATE: 19/10/2017

DAY: THURSDAY

TIME	MOVEMENT 3 FROM OAK LANE TO HIGH STREET (N)								MOVEMENT 4 FROM OAK LANE TO HIGH STREET (S)							
	CAR	LGV	OGV1	OGV2	PSV	MCL	PCL	TOT	CAR	LGV	OGV1	OGV2	PSV	MCL	PCL	TOT
07:00	1	2	0	0	0	0	0	3	6	1	0	0	0	0	0	7
07:15	1	1	0	0	0	0	0	2	3	2	0	0	0	0	0	5
07:30	3	1	0	0	0	0	0	4	1	0	0	0	0	0	0	1
07:45	5	0	0	0	0	0	0	5	6	1	0	0	0	0	0	7
H/TOT	10	4	0	0	0	0	0	14	16	4	0	0	0	0	0	20
08:00	6	0	0	0	0	0	0	6	9	2	0	0	0	0	0	11
08:15	4	1	0	0	0	0	0	5	3	0	1	0	0	0	0	4
08:30	10	0	0	0	0	0	0	10	2	0	0	0	0	0	0	2
08:45	4	0	0	0	0	0	0	4	15	0	0	0	0	0	0	15
H/TOT	24	1	0	0	0	0	0	25	29	2	1	0	0	0	0	32
09:00	3	0	0	0	0	0	0	3	19	0	0	0	0	0	0	19
09:15	1	1	0	0	0	0	0	2	4	2	1	0	0	0	0	7
09:30	3	0	0	0	0	0	0	3	4	0	0	0	0	0	0	4
09:45	2	0	0	0	0	0	0	2	4	0	0	0	0	0	0	4
H/TOT	9	1	0	0	0	0	0	10	31	2	1	0	0	0	0	34
P/TOT	43	6	0	0	0	0	0	49	76	8	2	0	0	0	0	86

MANUAL CLASSIFIED COUNTS



JOB REF: 22229

JOB NAME: GRAVELEY

SITE: 1

LOCATION: HIGH STREET / OAK LANE

DATE: 19/10/2017

DAY: THURSDAY

TIME	MOVEMENT 5 FROM HIGH STREET (S) TO OAK LANE								MOVEMENT 6 FROM HIGH STREET (S) TO HIGH STREET (N)							
	CAR	LGV	OGV1	OGV2	PSV	MCL	PCL	TOT	CAR	LGV	OGV1	OGV2	PSV	MCL	PCL	TOT
07:00	3	2	0	0	0	0	0	5	47	6	2	0	0	0	0	55
07:15	1	1	0	0	0	0	0	2	58	10	1	0	1	3	0	73
07:30	3	1	0	0	0	0	0	4	82	11	1	0	0	1	0	95
07:45	6	2	0	0	0	0	0	8	78	7	0	0	1	1	1	88
H/TOT	13	6	0	0	0	0	0	19	265	34	4	0	2	5	1	311
08:00	5	0	0	0	0	0	0	5	96	15	0	0	1	0	0	112
08:15	5	0	0	0	0	0	0	5	115	13	1	0	1	0	0	130
08:30	8	0	0	0	0	0	0	8	99	10	1	0	1	0	0	111
08:45	19	0	0	0	0	0	0	19	93	10	1	1	1	2	0	108
H/TOT	37	0	0	0	0	0	0	37	403	48	3	1	4	2	0	461
09:00	3	0	1	0	0	0	0	4	64	8	1	0	0	1	0	74
09:15	1	1	0	0	0	0	0	2	59	19	0	0	1	0	0	79
09:30	3	0	0	0	0	0	0	3	55	6	1	0	0	1	0	63
09:45	3	0	0	0	0	0	0	3	50	3	4	0	1	0	0	58
H/TOT	10	1	1	0	0	0	0	12	228	36	6	0	2	2	0	274
P/TOT	60	7	1	0	0	0	0	68	896	118	13	1	8	9	1	1046

MANUAL CLASSIFIED COUNTS



JOB REF: 22229

JOB NAME: GRAVELEY

SITE: 1

LOCATION: HIGH STREET / OAK LANE

DATE: 19/10/2017

DAY: THURSDAY

TIME	MOVEMENT 5 FROM HIGH STREET (S) TO OAK LANE							
	CAR	LGV	OGV1	OGV2	PSV	MCL	PCL	TOT
16:00	3	1	0	0	0	0	0	4
16:15	7	1	0	0	0	0	0	8
16:30	7	1	0	0	0	0	0	8
16:45	4	3	0	0	0	0	0	7
H/TOT	21	6	0	0	0	0	0	27
17:00	5	3	0	0	0	0	0	8
17:15	7	1	0	0	0	0	0	8
17:30	7	0	0	0	0	0	0	7
17:45	4	1	0	0	0	0	0	5
H/TOT	23	5	0	0	0	0	0	28
18:00	4	0	0	0	0	0	0	4
18:15	4	0	1	0	0	0	0	5
18:30	6	0	0	0	0	0	0	6
18:45	6	1	0	0	0	0	0	7
H/TOT	20	1	1	0	0	0	0	22
P/TOT	64	12	1	0	0	0	0	77

TIME	MOVEMENT 6 FROM HIGH STREET (S) TO HIGH STREET (N)							
	CAR	LGV	OGV1	OGV2	PSV	MCL	PCL	TOT
16:00	90	10	1	0	0	1	1	103
16:15	112	8	2	1	1	2	0	126
16:30	95	10	1	0	0	0	0	106
16:45	111	7	1	0	1	1	0	121
H/TOT	408	35	5	1	2	4	1	456
17:00	120	7	3	0	0	0	0	130
17:15	105	4	2	0	1	0	1	113
17:30	104	5	0	0	0	5	1	115
17:45	108	11	1	0	1	0	3	124
H/TOT	437	27	6	0	2	5	5	482
18:00	73	2	1	0	3	1	0	80
18:15	79	4	0	0	0	0	3	86
18:30	72	4	1	0	1	0	0	78
18:45	59	0	0	0	1	0	0	60
H/TOT	283	10	2	0	5	1	3	304
P/TOT	1128	72	13	1	9	10	9	1242

MANUAL CLASSIFIED COUNTS



JOB REF: 22229

JOB NAME: GRAVELEY

SITE: 1

LOCATION: HIGH STREET / OAK LANE

DATE: 19/10/2017

DAY: THURSDAY

TIME	TO ARM A HIGH STREET (N)								FROM ARM A HIGH STREET (N)							
	CAR	LGV	OGV1	OGV2	PSV	MCL	PCL	TOT	CAR	LGV	OGV1	OGV2	PSV	MCL	PCL	TOT
07:00	48	8	2	0	0	0	0	58	114	17	0	0	1	0	0	132
07:15	59	11	1	0	1	3	0	75	206	15	4	0	2	3	1	231
07:30	85	12	1	0	0	1	0	99	270	16	3	1	0	0	2	292
07:45	83	7	0	0	1	1	1	93	308	19	1	0	1	4	0	333
H/TOT	275	38	4	0	2	5	1	325	898	67	8	1	4	7	3	988
08:00	102	15	0	0	1	0	0	118	296	17	4	0	0	1	2	320
08:15	119	14	1	0	1	0	0	135	236	24	6	0	2	2	2	272
08:30	109	10	1	0	1	0	0	121	249	19	4	0	3	1	0	276
08:45	97	10	1	1	1	2	0	112	258	16	2	1	1	1	0	279
H/TOT	427	49	3	1	4	2	0	486	1039	76	16	1	6	5	4	1147
09:00	67	8	1	0	0	1	0	77	256	18	4	2	0	0	1	281
09:15	60	20	0	0	1	0	0	81	132	11	5	0	1	0	1	150
09:30	58	6	1	0	0	1	0	66	76	10	1	0	1	0	0	88
09:45	52	3	4	0	1	0	0	60	59	10	4	0	1	0	0	74
H/TOT	237	37	6	0	2	2	0	284	523	49	14	2	3	0	2	593
P/TOT	939	124	13	1	8	9	1	1095	2460	192	38	4	13	12	9	2728

MANUAL CLASSIFIED COUNTS



JOB REF: 22229

JOB NAME: GRAVELEY

SITE: 1

LOCATION: HIGH STREET / OAK LANE

DATE: 19/10/2017

DAY: THURSDAY

TIME	TO ARM A HIGH STREET (N)								FROM ARM A HIGH STREET (N)							
	CAR	LGV	OGV1	OGV2	PSV	MCL	PCL	TOT	CAR	LGV	OGV1	OGV2	PSV	MCL	PCL	TOT
16:00	98	10	1	0	0	1	1	111	78	10	3	0	0	2	0	93
16:15	115	8	2	1	1	2	0	129	71	11	4	0	1	0	0	87
16:30	96	10	1	0	0	0	0	107	80	15	3	0	0	1	0	99
16:45	113	8	1	0	1	1	0	124	75	24	2	0	1	1	0	103
H/TOT	422	36	5	1	2	4	1	471	304	60	12	0	2	4	0	382
17:00	120	7	3	0	0	0	0	130	100	12	2	0	0	1	1	116
17:15	107	4	2	0	1	0	1	115	105	9	4	0	2	2	1	123
17:30	107	5	0	0	0	5	1	118	91	8	3	0	0	4	0	106
17:45	112	12	1	0	1	0	3	129	90	11	1	0	1	0	0	103
H/TOT	446	28	6	0	2	5	5	492	386	40	10	0	3	7	2	448
18:00	75	3	1	0	3	1	0	83	69	5	0	0	0	1	0	75
18:15	81	4	0	0	0	0	3	88	66	4	0	0	1	1	0	72
18:30	72	4	1	0	1	0	0	78	67	1	0	0	0	1	0	69
18:45	60	0	0	0	1	0	0	61	48	0	0	0	1	0	0	49
H/TOT	288	11	2	0	5	1	3	310	250	10	0	0	2	3	0	265
P/TOT	1156	75	13	1	9	10	9	1273	940	110	22	0	7	14	2	1095

TO ARM A IS TOTAL OF MOVEMENTS 3, 6

FROM ARM A IS TOTAL OF MOVEMENTS 1, 2

MANUAL CLASSIFIED COUNTS

JOB REF: 22229

JOB NAME: GRAVELEY

SITE: 1

LOCATION: HIGH STREET / OAK LANE



DATE: 19/10/2017

DAY: THURSDAY

TIME	TO ARM B OAK LANE								FROM ARM B OAK LANE							
	CAR	LGV	OGV1	OGV2	PSV	MCL	PCL	TOT	CAR	LGV	OGV1	OGV2	PSV	MCL	PCL	TOT
07:00	4	2	0	0	0	0	0	6	7	3	0	0	0	0	0	10
07:15	2	1	0	0	0	0	0	3	4	3	0	0	0	0	0	7
07:30	5	1	0	0	0	0	0	6	4	1	0	0	0	0	0	5
07:45	11	2	0	0	0	0	0	13	11	1	0	0	0	0	0	12
H/TOT	22	6	0	0	0	0	0	28	26	8	0	0	0	0	0	34
08:00	11	1	0	0	0	0	0	12	15	2	0	0	0	0	0	17
08:15	12	0	0	0	0	0	0	12	7	1	1	0	0	0	0	9
08:30	13	0	0	0	0	0	0	13	12	0	0	0	0	0	0	12
08:45	24	0	0	0	0	0	0	24	19	0	0	0	0	0	0	19
H/TOT	60	1	0	0	0	0	0	61	53	3	1	0	0	0	0	57
09:00	6	0	1	0	0	0	0	7	22	0	0	0	0	0	0	22
09:15	3	2	0	0	0	0	0	5	5	3	1	0	0	0	0	9
09:30	6	0	0	0	0	0	0	6	7	0	0	0	0	0	0	7
09:45	4	1	0	0	0	0	0	5	6	0	0	0	0	0	0	6
H/TOT	19	3	1	0	0	0	0	23	40	3	1	0	0	0	0	44
P/TOT	101	10	1	0	0	0	0	112	119	14	2	0	0	0	0	135

MANUAL CLASSIFIED COUNTS



JOB REF: 22229

JOB NAME: GRAVELEY

SITE: 1

LOCATION: HIGH STREET / OAK LANE

DATE: 19/10/2017

DAY: THURSDAY

TIME	TO ARM B OAK LANE								FROM ARM B OAK LANE							
	CAR	LGV	OGV1	OGV2	PSV	MCL	PCL	TOT	CAR	LGV	OGV1	OGV2	PSV	MCL	PCL	TOT
16:00	4	2	0	0	0	0	0	6	10	1	0	0	0	0	0	11
16:15	8	1	0	0	0	0	0	9	6	2	0	0	0	0	0	8
16:30	9	1	0	0	0	0	0	10	5	1	0	0	0	0	0	6
16:45	6	3	0	0	0	0	0	9	6	2	0	0	0	0	0	8
H/TOT	27	7	0	0	0	0	0	34	27	6	0	0	0	0	0	33
17:00	6	4	0	0	0	0	0	10	1	0	0	0	0	0	0	1
17:15	10	1	0	0	0	0	0	11	5	1	0	0	0	0	0	6
17:30	11	0	0	0	0	0	0	11	7	0	0	0	0	0	0	7
17:45	5	2	0	0	0	0	0	7	8	2	0	0	0	0	0	10
H/TOT	32	7	0	0	0	0	0	39	21	3	0	0	0	0	0	24
18:00	7	0	0	0	0	0	0	7	5	1	0	0	0	0	0	6
18:15	6	0	1	0	0	0	0	7	3	0	0	0	0	0	0	3
18:30	8	0	0	0	0	0	0	8	3	0	0	0	0	0	0	3
18:45	6	1	0	0	0	0	0	7	5	0	0	0	0	0	0	5
H/TOT	27	1	1	0	0	0	0	29	16	1	0	0	0	0	0	17
P/TOT	86	15	1	0	0	0	0	102	64	10	0	0	0	0	0	74

TO ARM B IS TOTAL OF MOVEMENTS 2, 5
 FROM ARM B IS TOTAL OF MOVEMENTS 3, 4

MANUAL CLASSIFIED COUNTS

JOB REF: 22229

JOB NAME: GRAVELEY

SITE: 1

LOCATION: HIGH STREET / OAK LANE



DATE: 19/10/2017

DAY: THURSDAY

TIME	TO ARM C HIGH STREET (S)								FROM ARM C HIGH STREET (S)							
	CAR	LGV	OGV1	OGV2	PSV	MCL	PCL	TOT	CAR	LGV	OGV1	OGV2	PSV	MCL	PCL	TOT
07:00	119	18	0	0	1	0	0	138	50	8	2	0	0	0	0	60
07:15	208	17	4	0	2	3	1	235	59	11	1	0	1	3	0	75
07:30	269	16	3	1	0	0	2	291	85	12	1	0	0	1	0	99
07:45	309	20	1	0	1	4	0	335	84	9	0	0	1	1	1	96
H/TOT	905	71	8	1	4	7	3	999	278	40	4	0	2	5	1	330
08:00	299	18	4	0	0	1	2	324	101	15	0	0	1	0	0	117
08:15	232	24	7	0	2	2	2	269	120	13	1	0	1	0	0	135
08:30	246	19	4	0	3	1	0	273	107	10	1	0	1	0	0	119
08:45	268	16	2	1	1	1	0	289	112	10	1	1	1	2	0	127
H/TOT	1045	77	17	1	6	5	4	1155	440	48	3	1	4	2	0	498
09:00	272	18	4	2	0	0	1	297	67	8	2	0	0	1	0	78
09:15	134	12	6	0	1	0	1	154	60	20	0	0	1	0	0	81
09:30	77	10	1	0	1	0	0	89	58	6	1	0	0	1	0	66
09:45	62	9	4	0	1	0	0	76	53	3	4	0	1	0	0	61
H/TOT	545	49	15	2	3	0	2	616	238	37	7	0	2	2	0	286
P/TOT	2495	197	40	4	13	12	9	2770	956	125	14	1	8	9	1	1114

MANUAL CLASSIFIED COUNTS



JOB REF: 22229

JOB NAME: GRAVELEY

SITE: 1

LOCATION: HIGH STREET / OAK LANE

DATE: 19/10/2017

DAY: THURSDAY

TIME	TO ARM C HIGH STREET (S)								FROM ARM C HIGH STREET (S)							
	CAR	LGV	OGV1	OGV2	PSV	MCL	PCL	TOT	CAR	LGV	OGV1	OGV2	PSV	MCL	PCL	TOT
16:00	79	10	3	0	0	2	0	94	93	11	1	0	0	1	1	107
16:15	73	13	4	0	1	0	0	91	119	9	2	1	1	2	0	134
16:30	82	16	3	0	0	1	0	102	102	11	1	0	0	0	0	114
16:45	77	25	2	0	1	1	0	106	115	10	1	0	1	1	0	128
H/TOT	311	64	12	0	2	4	0	393	429	41	5	1	2	4	1	483
17:00	100	11	2	0	0	1	1	115	125	10	3	0	0	0	0	138
17:15	105	10	4	0	2	2	1	124	112	5	2	0	1	0	1	121
17:30	91	8	3	0	0	4	0	106	111	5	0	0	0	5	1	122
17:45	93	11	1	0	1	0	0	106	112	12	1	0	1	0	3	129
H/TOT	389	40	10	0	3	7	2	451	460	32	6	0	2	5	5	510
18:00	69	5	0	0	0	1	0	75	77	2	1	0	3	1	0	84
18:15	65	4	0	0	1	1	0	71	83	4	1	0	0	0	3	91
18:30	68	1	0	0	0	1	0	70	78	4	1	0	1	0	0	84
18:45	52	0	0	0	1	0	0	53	65	1	0	0	1	0	0	67
H/TOT	254	10	0	0	2	3	0	269	303	11	3	0	5	1	3	326
P/TOT	954	114	22	0	7	14	2	1113	1192	84	14	1	9	10	9	1319

TO ARM C IS TOTAL OF MOVEMENTS 1, 4

FROM ARM C IS TOTAL OF MOVEMENTS 5, 6

MANUAL CLASSIFIED COUNTS



JOB REF: 22229

JOB NAME: GRAVELEY

SITE: 2

LOCATION: HIGH STREET / CHURCH LANE

DATE: 19/10/2017

DAY: THURSDAY

TIME	MOVEMENT 1 FROM HIGH STREET (N) TO CHURCH LANE							
	CAR	LGV	OGV1	OGV2	PSV	MCL	PCL	TOT
07:00	1	0	0	0	0	0	0	1
07:15	2	0	0	0	0	0	0	2
07:30	1	1	0	0	0	0	0	2
07:45	3	0	0	0	0	0	0	3
H/TOT	7	1	0	0	0	0	0	8
08:00	5	0	0	0	0	0	0	5
08:15	0	2	0	0	0	0	0	2
08:30	1	0	0	0	0	0	0	1
08:45	3	1	0	0	0	0	0	4
H/TOT	9	3	0	0	0	0	0	12
09:00	3	0	0	0	0	0	0	3
09:15	4	1	0	0	0	0	0	5
09:30	4	0	0	0	0	0	0	4
09:45	3	0	0	0	0	0	0	3
H/TOT	14	1	0	0	0	0	0	15
P/TOT	30	5	0	0	0	0	0	35

TIME	MOVEMENT 2 FROM HIGH STREET (N) TO HIGH STREET (S)							
	CAR	LGV	OGV1	OGV2	PSV	MCL	PCL	TOT
07:00	113	17	0	0	1	0	0	131
07:15	202	14	4	0	2	3	1	226
07:30	267	16	3	1	0	0	2	289
07:45	299	18	1	0	1	4	0	323
H/TOT	881	65	8	1	4	7	3	969
08:00	290	17	4	0	0	1	2	314
08:15	231	24	6	0	2	2	2	267
08:30	246	18	4	0	3	1	0	272
08:45	253	16	2	1	1	1	0	274
H/TOT	1020	75	16	1	6	5	4	1127
09:00	249	18	4	2	0	0	1	274
09:15	128	11	5	0	1	0	1	146
09:30	74	9	1	0	1	0	0	85
09:45	58	9	4	0	1	0	0	72
H/TOT	509	47	14	2	3	0	2	577
P/TOT	2410	187	38	4	13	12	9	2673

MANUAL CLASSIFIED COUNTS



JOB REF: 22229

JOB NAME: GRAVELEY

SITE: 2

LOCATION: HIGH STREET / CHURCH LANE

DATE: 19/10/2017

DAY: THURSDAY

TIME	MOVEMENT 1 FROM HIGH STREET (N) TO CHURCH LANE								MOVEMENT 2 FROM HIGH STREET (N) TO HIGH STREET (S)							
	CAR	LGV	OGV1	OGV2	PSV	MCL	PCL	TOT	CAR	LGV	OGV1	OGV2	PSV	MCL	PCL	TOT
16:00	2	0	0	0	0	0	0	2	72	9	3	0	0	2	0	86
16:15	3	0	0	0	0	0	0	3	67	11	4	0	1	0	0	83
16:30	3	0	0	0	0	0	0	3	78	14	3	0	0	1	0	96
16:45	6	0	0	0	0	0	0	6	74	22	2	0	1	1	0	100
H/TOT	14	0	0	0	0	0	0	14	291	56	12	0	2	4	0	365
17:00	3	0	0	0	0	0	0	3	94	11	2	0	0	1	1	109
17:15	6	0	0	0	0	0	0	6	102	8	4	0	2	2	1	119
17:30	3	0	0	0	0	0	0	3	86	8	3	0	0	4	0	101
17:45	6	1	0	0	0	0	0	7	89	10	1	0	1	0	0	101
H/TOT	18	1	0	0	0	0	0	19	371	37	10	0	3	7	2	430
18:00	2	1	0	0	0	0	0	3	65	4	0	0	0	1	0	70
18:15	2	1	0	0	0	0	0	3	65	4	0	0	1	1	0	71
18:30	3	2	0	0	0	0	0	5	65	1	0	0	0	1	0	67
18:45	0	0	0	0	0	0	0	0	44	0	0	0	1	0	0	45
H/TOT	7	4	0	0	0	0	0	11	239	9	0	0	2	3	0	253
P/TOT	39	5	0	0	0	0	0	44	901	102	22	0	7	14	2	1048

MANUAL CLASSIFIED COUNTS



JOB REF: 22229

JOB NAME: GRAVELEY

SITE: 2

LOCATION: HIGH STREET / CHURCH LANE

DATE: 19/10/2017

DAY: THURSDAY

TIME	MOVEMENT 3 FROM HIGH STREET (S) TO HIGH STREET (N)								MOVEMENT 4 FROM HIGH STREET (S) TO CHURCH LANE							
	CAR	LGV	OGV1	OGV2	PSV	MCL	PCL	TOT	CAR	LGV	OGV1	OGV2	PSV	MCL	PCL	TOT
07:00	48	8	2	0	0	0	0	58	0	0	0	0	0	0	0	0
07:15	59	11	1	0	1	3	0	75	0	0	0	0	0	0	0	0
07:30	82	12	1	0	0	1	0	96	3	0	0	0	0	0	0	3
07:45	83	6	0	0	1	1	1	92	0	1	0	0	0	0	0	1
H/TOT	272	37	4	0	2	5	1	321	3	1	0	0	0	0	0	4
08:00	101	15	0	0	1	0	0	117	1	0	0	0	0	0	0	1
08:15	118	13	1	0	1	0	0	133	1	1	0	0	0	0	0	2
08:30	106	10	1	0	1	0	0	118	3	0	0	0	0	0	0	3
08:45	93	10	1	1	1	2	0	108	4	0	0	0	0	0	0	4
H/TOT	418	48	3	1	4	2	0	476	9	1	0	0	0	0	0	10
09:00	64	7	1	0	0	1	0	73	3	1	0	0	0	0	0	4
09:15	56	20	0	0	1	0	0	77	4	0	0	0	0	0	0	4
09:30	53	5	1	0	0	1	0	60	5	1	0	0	0	0	0	6
09:45	49	3	2	0	1	0	0	55	3	0	2	0	0	0	0	5
H/TOT	222	35	4	0	2	2	0	265	15	2	2	0	0	0	0	19
P/TOT	912	120	11	1	8	9	1	1062	27	4	2	0	0	0	0	33

MANUAL CLASSIFIED COUNTS



JOB REF: 22229

JOB NAME: GRAVELEY

SITE: 2

LOCATION: HIGH STREET / CHURCH LANE

DATE: 19/10/2017

DAY: THURSDAY

TIME	MOVEMENT 3 FROM HIGH STREET (S) TO HIGH STREET (N)							
	CAR	LGV	OGV1	OGV2	PSV	MCL	PCL	TOT
16:00	92	10	1	0	0	1	1	105
16:15	113	7	2	1	1	2	0	126
16:30	93	7	1	0	0	0	0	101
16:45	111	7	1	0	1	1	0	121
H/TOT	409	31	5	1	2	4	1	453
17:00	117	6	3	0	0	0	0	126
17:15	104	4	2	0	1	0	1	112
17:30	103	5	0	0	0	5	1	114
17:45	106	10	1	0	1	0	3	121
H/TOT	430	25	6	0	2	5	5	473
18:00	69	2	1	0	3	1	0	76
18:15	78	3	0	0	0	0	3	84
18:30	71	4	0	0	1	0	0	76
18:45	53	0	0	0	1	0	0	54
H/TOT	271	9	1	0	5	1	3	290
P/TOT	1110	65	12	1	9	10	9	1216

TIME	MOVEMENT 4 FROM HIGH STREET (S) TO CHURCH LANE							
	CAR	LGV	OGV1	OGV2	PSV	MCL	PCL	TOT
16:00	6	0	0	0	0	0	0	6
16:15	2	1	0	0	0	0	0	3
16:30	3	3	0	0	0	0	0	6
16:45	2	1	0	0	0	0	0	3
H/TOT	13	5	0	0	0	0	0	18
17:00	3	1	0	0	0	0	0	4
17:15	3	0	0	0	0	0	0	3
17:30	4	0	0	0	0	0	0	4
17:45	6	2	0	0	0	0	0	8
H/TOT	16	3	0	0	0	0	0	19
18:00	6	1	0	0	0	0	0	7
18:15	3	1	0	0	0	0	0	4
18:30	1	0	1	0	0	0	0	2
18:45	7	0	0	0	0	0	0	7
H/TOT	17	2	1	0	0	0	0	20
P/TOT	46	10	1	0	0	0	0	57

MANUAL CLASSIFIED COUNTS



JOB REF: 22229

JOB NAME: GRAVELEY

SITE: 2

LOCATION: HIGH STREET / CHURCH LANE

DATE: 19/10/2017

DAY: THURSDAY

TIME	MOVEMENT 5 FROM CHURCH LANE TO HIGH STREET (S)								MOVEMENT 6 FROM CHURCH LANE TO HIGH STREET (N)							
	CAR	LGV	OGV1	OGV2	PSV	MCL	PCL	TOT	CAR	LGV	OGV1	OGV2	PSV	MCL	PCL	TOT
07:00	1	0	0	0	0	0	0	1	6	1	0	0	0	0	0	7
07:15	4	1	0	0	0	0	0	5	5	0	0	0	0	0	1	6
07:30	3	0	0	0	0	0	0	3	10	0	0	0	0	0	0	10
07:45	9	1	0	0	0	0	0	10	14	5	0	0	0	0	0	19
H/TOT	17	2	0	0	0	0	0	19	35	6	0	0	0	0	1	42
08:00	6	0	0	0	0	0	0	6	14	0	0	0	0	0	0	14
08:15	5	0	0	0	0	0	0	5	26	6	0	0	0	0	0	32
08:30	3	1	0	0	0	0	0	4	10	0	1	0	0	0	0	11
08:45	5	0	0	0	0	0	0	5	6	1	1	0	0	0	0	8
H/TOT	19	1	0	0	0	0	0	20	56	7	2	0	0	0	0	65
09:00	7	0	0	0	0	0	0	7	3	1	0	0	0	0	0	4
09:15	4	0	0	0	0	0	0	4	3	1	0	0	0	0	0	4
09:30	2	1	0	0	0	0	0	3	1	0	0	0	0	0	0	1
09:45	1	1	0	0	0	0	0	2	5	1	0	0	0	0	0	6
H/TOT	14	2	0	0	0	0	0	16	12	3	0	0	0	0	0	15
P/TOT	50	5	0	0	0	0	0	55	103	16	2	0	0	0	1	122

MANUAL CLASSIFIED COUNTS



JOB REF: 22229

JOB NAME: GRAVELEY

SITE: 2

LOCATION: HIGH STREET / CHURCH LANE

DATE: 19/10/2017

DAY: THURSDAY

TIME	MOVEMENT 5 FROM CHURCH LANE TO HIGH STREET (S)								MOVEMENT 6 FROM CHURCH LANE TO HIGH STREET (N)							
	CAR	LGV	OGV1	OGV2	PSV	MCL	PCL	TOT	CAR	LGV	OGV1	OGV2	PSV	MCL	PCL	TOT
16:00	6	1	0	0	0	0	0	7	1	0	1	0	0	0	0	2
16:15	4	0	0	0	0	0	0	4	4	3	0	0	0	0	0	7
16:30	2	1	0	0	0	0	0	3	1	0	0	0	0	0	0	1
16:45	1	2	0	0	0	0	0	3	2	2	0	0	0	0	0	4
H/TOT	13	4	0	0	0	0	0	17	8	5	1	0	0	0	0	14
17:00	6	1	0	0	0	0	0	7	2	0	1	0	0	0	0	3
17:15	3	1	0	0	0	0	0	4	7	0	0	0	0	0	0	7
17:30	5	0	0	0	0	0	0	5	2	0	0	0	0	0	0	2
17:45	1	1	0	0	0	0	0	2	0	0	0	0	0	0	0	0
H/TOT	15	3	0	0	0	0	0	18	11	0	1	0	0	0	0	12
18:00	4	1	0	0	0	0	0	5	0	0	0	0	0	0	0	0
18:15	1	0	0	0	0	0	0	1	0	2	0	0	0	0	0	2
18:30	2	0	0	0	0	0	0	2	3	1	0	0	0	0	0	4
18:45	4	0	0	0	0	0	0	4	3	0	0	0	0	0	0	3
H/TOT	11	1	0	0	0	0	0	12	6	3	0	0	0	0	0	9
P/TOT	39	8	0	0	0	0	0	47	25	8	2	0	0	0	0	35

MANUAL CLASSIFIED COUNTS



JOB REF: 22229

JOB NAME: GRAVELEY

SITE: 2

LOCATION: HIGH STREET / CHURCH LANE

DATE: 19/10/2017

DAY: THURSDAY

TIME	TO ARM A HIGH STREET (N)								FROM ARM A HIGH STREET (N)							
	CAR	LGV	OGV1	OGV2	PSV	MCL	PCL	TOT	CAR	LGV	OGV1	OGV2	PSV	MCL	PCL	TOT
07:00	54	9	2	0	0	0	0	65	114	17	0	0	1	0	0	132
07:15	64	11	1	0	1	3	1	81	204	14	4	0	2	3	1	228
07:30	92	12	1	0	0	1	0	106	268	17	3	1	0	0	2	291
07:45	97	11	0	0	1	1	1	111	302	18	1	0	1	4	0	326
H/TOT	307	43	4	0	2	5	2	363	888	66	8	1	4	7	3	977
08:00	115	15	0	0	1	0	0	131	295	17	4	0	0	1	2	319
08:15	144	19	1	0	1	0	0	165	231	26	6	0	2	2	2	269
08:30	116	10	2	0	1	0	0	129	247	18	4	0	3	1	0	273
08:45	99	11	2	1	1	2	0	116	256	17	2	1	1	1	0	278
H/TOT	474	55	5	1	4	2	0	541	1029	78	16	1	6	5	4	1139
09:00	67	8	1	0	0	1	0	77	252	18	4	2	0	0	1	277
09:15	59	21	0	0	1	0	0	81	132	12	5	0	1	0	1	151
09:30	54	5	1	0	0	1	0	61	78	9	1	0	1	0	0	89
09:45	54	4	2	0	1	0	0	61	61	9	4	0	1	0	0	75
H/TOT	234	38	4	0	2	2	0	280	523	48	14	2	3	0	2	592
P/TOT	1015	136	13	1	8	9	2	1184	2440	192	38	4	13	12	9	2708

MANUAL CLASSIFIED COUNTS



JOB REF: 22229

JOB NAME: GRAVELEY

SITE: 2

LOCATION: HIGH STREET / CHURCH LANE

DATE: 19/10/2017

DAY: THURSDAY

TIME	TO ARM A HIGH STREET (N)								FROM ARM A HIGH STREET (N)							
	CAR	LGV	OGV1	OGV2	PSV	MCL	PCL	TOT	CAR	LGV	OGV1	OGV2	PSV	MCL	PCL	TOT
16:00	93	10	2	0	0	1	1	107	74	9	3	0	0	2	0	88
16:15	117	10	2	1	1	2	0	133	70	11	4	0	1	0	0	86
16:30	94	7	1	0	0	0	0	102	81	14	3	0	0	1	0	99
16:45	113	9	1	0	1	1	0	125	80	22	2	0	1	1	0	106
H/TOT	417	36	6	1	2	4	1	467	305	56	12	0	2	4	0	379
17:00	119	6	4	0	0	0	0	129	97	11	2	0	0	1	1	112
17:15	111	4	2	0	1	0	1	119	108	8	4	0	2	2	1	125
17:30	105	5	0	0	0	5	1	116	89	8	3	0	0	4	0	104
17:45	106	10	1	0	1	0	3	121	95	11	1	0	1	0	0	108
H/TOT	441	25	7	0	2	5	5	485	389	38	10	0	3	7	2	449
18:00	69	2	1	0	3	1	0	76	67	5	0	0	0	1	0	73
18:15	78	5	0	0	0	0	3	86	67	5	0	0	1	1	0	74
18:30	74	5	0	0	1	0	0	80	68	3	0	0	0	1	0	72
18:45	56	0	0	0	1	0	0	57	44	0	0	0	1	0	0	45
H/TOT	277	12	1	0	5	1	3	299	246	13	0	0	2	3	0	264
P/TOT	1135	73	14	1	9	10	9	1251	940	107	22	0	7	14	2	1092

TO ARM A IS TOTAL OF MOVEMENTS 3, 6

FROM ARM A IS TOTAL OF MOVEMENTS 1, 2

MANUAL CLASSIFIED COUNTS



JOB REF: 22229

JOB NAME: GRAVELEY

SITE: 2

LOCATION: HIGH STREET / CHURCH LANE

DATE: 19/10/2017

DAY: THURSDAY

TIME	TO ARM B HIGH STREET (S)								FROM ARM B HIGH STREET (S)							
	CAR	LGV	OGV1	OGV2	PSV	MCL	PCL	TOT	CAR	LGV	OGV1	OGV2	PSV	MCL	PCL	TOT
07:00	114	17	0	0	1	0	0	132	48	8	2	0	0	0	0	58
07:15	206	15	4	0	2	3	1	231	59	11	1	0	1	3	0	75
07:30	270	16	3	1	0	0	2	292	85	12	1	0	0	1	0	99
07:45	308	19	1	0	1	4	0	333	83	7	0	0	1	1	1	93
H/TOT	898	67	8	1	4	7	3	988	275	38	4	0	2	5	1	325
08:00	296	17	4	0	0	1	2	320	102	15	0	0	1	0	0	118
08:15	236	24	6	0	2	2	2	272	119	14	1	0	1	0	0	135
08:30	249	19	4	0	3	1	0	276	109	10	1	0	1	0	0	121
08:45	258	16	2	1	1	1	0	279	97	10	1	1	1	2	0	112
H/TOT	1039	76	16	1	6	5	4	1147	427	49	3	1	4	2	0	486
09:00	256	18	4	2	0	0	1	281	67	8	1	0	0	1	0	77
09:15	132	11	5	0	1	0	1	150	60	20	0	0	1	0	0	81
09:30	76	10	1	0	1	0	0	88	58	6	1	0	0	1	0	66
09:45	59	10	4	0	1	0	0	74	52	3	4	0	1	0	0	60
H/TOT	523	49	14	2	3	0	2	593	237	37	6	0	2	2	0	284
P/TOT	2460	192	38	4	13	12	9	2728	939	124	13	1	8	9	1	1095

MANUAL CLASSIFIED COUNTS



JOB REF: 22229

JOB NAME: GRAVELEY

SITE: 2

LOCATION: HIGH STREET / CHURCH LANE

DATE: 19/10/2017

DAY: THURSDAY

TIME	TO ARM B HIGH STREET (S)								FROM ARM B HIGH STREET (S)							
	CAR	LGV	OGV1	OGV2	PSV	MCL	PCL	TOT	CAR	LGV	OGV1	OGV2	PSV	MCL	PCL	TOT
16:00	78	10	3	0	0	2	0	93	98	10	1	0	0	1	1	111
16:15	71	11	4	0	1	0	0	87	115	8	2	1	1	2	0	129
16:30	80	15	3	0	0	1	0	99	96	10	1	0	0	0	0	107
16:45	75	24	2	0	1	1	0	103	113	8	1	0	1	1	0	124
H/TOT	304	60	12	0	2	4	0	382	422	36	5	1	2	4	1	471
17:00	100	12	2	0	0	1	1	116	120	7	3	0	0	0	0	130
17:15	105	9	4	0	2	2	1	123	107	4	2	0	1	0	1	115
17:30	91	8	3	0	0	4	0	106	107	5	0	0	0	5	1	118
17:45	90	11	1	0	1	0	0	103	112	12	1	0	1	0	3	129
H/TOT	386	40	10	0	3	7	2	448	446	28	6	0	2	5	5	492
18:00	69	5	0	0	0	1	0	75	75	3	1	0	3	1	0	83
18:15	66	4	0	0	1	1	0	72	81	4	0	0	0	0	3	88
18:30	67	1	0	0	0	1	0	69	72	4	1	0	1	0	0	78
18:45	48	0	0	0	1	0	0	49	60	0	0	0	1	0	0	61
H/TOT	250	10	0	0	2	3	0	265	288	11	2	0	5	1	3	310
P/TOT	940	110	22	0	7	14	2	1095	1156	75	13	1	9	10	9	1273

TO ARM B IS TOTAL OF MOVEMENTS 2, 5

FROM ARM B IS TOTAL OF MOVEMENTS 3, 4

MANUAL CLASSIFIED COUNTS



JOB REF: 22229

JOB NAME: GRAVELEY

SITE: 2

LOCATION: HIGH STREET / CHURCH LANE

DATE: 19/10/2017

DAY: THURSDAY

TIME	TO ARM C CHURCH LANE								FROM ARM C CHURCH LANE							
	CAR	LGV	OGV1	OGV2	PSV	MCL	PCL	TOT	CAR	LGV	OGV1	OGV2	PSV	MCL	PCL	TOT
07:00	1	0	0	0	0	0	0	1	7	1	0	0	0	0	0	8
07:15	2	0	0	0	0	0	0	2	9	1	0	0	0	0	1	11
07:30	4	1	0	0	0	0	0	5	13	0	0	0	0	0	0	13
07:45	3	1	0	0	0	0	0	4	23	6	0	0	0	0	0	29
H/TOT	10	2	0	0	0	0	0	12	52	8	0	0	0	0	1	61
08:00	6	0	0	0	0	0	0	6	20	0	0	0	0	0	0	20
08:15	1	3	0	0	0	0	0	4	31	6	0	0	0	0	0	37
08:30	4	0	0	0	0	0	0	4	13	1	1	0	0	0	0	15
08:45	7	1	0	0	0	0	0	8	11	1	1	0	0	0	0	13
H/TOT	18	4	0	0	0	0	0	22	75	8	2	0	0	0	0	85
09:00	6	1	0	0	0	0	0	7	10	1	0	0	0	0	0	11
09:15	8	1	0	0	0	0	0	9	7	1	0	0	0	0	0	8
09:30	9	1	0	0	0	0	0	10	3	1	0	0	0	0	0	4
09:45	6	0	2	0	0	0	0	8	6	2	0	0	0	0	0	8
H/TOT	29	3	2	0	0	0	0	34	26	5	0	0	0	0	0	31
P/TOT	57	9	2	0	0	0	0	68	153	21	2	0	0	0	1	177

MANUAL CLASSIFIED COUNTS



JOB REF: 22229

JOB NAME: GRAVELEY

SITE: 2

LOCATION: HIGH STREET / CHURCH LANE

DATE: 19/10/2017

DAY: THURSDAY

TIME	TO ARM C CHURCH LANE								FROM ARM C CHURCH LANE							
	CAR	LGV	OGV1	OGV2	PSV	MCL	PCL	TOT	CAR	LGV	OGV1	OGV2	PSV	MCL	PCL	TOT
16:00	8	0	0	0	0	0	0	8	7	1	1	0	0	0	0	9
16:15	5	1	0	0	0	0	0	6	8	3	0	0	0	0	0	11
16:30	6	3	0	0	0	0	0	9	3	1	0	0	0	0	0	4
16:45	8	1	0	0	0	0	0	9	3	4	0	0	0	0	0	7
H/TOT	27	5	0	0	0	0	0	32	21	9	1	0	0	0	0	31
17:00	6	1	0	0	0	0	0	7	8	1	1	0	0	0	0	10
17:15	9	0	0	0	0	0	0	9	10	1	0	0	0	0	0	11
17:30	7	0	0	0	0	0	0	7	7	0	0	0	0	0	0	7
17:45	12	3	0	0	0	0	0	15	1	1	0	0	0	0	0	2
H/TOT	34	4	0	0	0	0	0	38	26	3	1	0	0	0	0	30
18:00	8	2	0	0	0	0	0	10	4	1	0	0	0	0	0	5
18:15	5	2	0	0	0	0	0	7	1	2	0	0	0	0	0	3
18:30	4	2	1	0	0	0	0	7	5	1	0	0	0	0	0	6
18:45	7	0	0	0	0	0	0	7	7	0	0	0	0	0	0	7
H/TOT	24	6	1	0	0	0	0	31	17	4	0	0	0	0	0	21
P/TOT	85	15	1	0	0	0	0	101	64	16	2	0	0	0	0	82

TO ARM C IS TOTAL OF MOVEMENTS 1, 4

FROM ARM C IS TOTAL OF MOVEMENTS 5, 6

QUEUE LENGTHS



JOB REF: 22229

JOB NAME: GRAVELEY

SITE: 2

DATE: 19/10/2017

LOCATION: HIGH STREET / CHURCH LANE

DAY: THURSDAY

NOTE: Queue Lengths recorded by the number of vehicles queuing at each 5-minute interval, by lane
 **1 denotes queues that stretched back to Site 1

TIME	ARM A	ARM B	ARM C	TIME	ARM A	ARM B	ARM C
	(A)	(C)	(A)		(A)	(C)	(A)
	LANE 1	LANE 1	LANE 1		LANE 1	LANE 1	LANE 1
07:00	0	0	0	16:00	0	0	1
07:05	0	0	0	16:05	0	0	0
07:10	0	0	0	16:10	0	0	0
07:15	0	0	0	16:15	0	0	0
07:20	0	0	0	16:20	0	0	0
07:25	0	0	0	16:25	0	0	0
07:30	0	0	0	16:30	0	0	0
07:35	0	0	0	16:35	0	7*	0
07:40	0	4	1	16:40	0	0	0
07:45	0	0	3	16:45	0	0	3
07:50	0	0	2	16:50	0	0	0
07:55	0	0	1	16:55	0	0	0
08:00	0	0	2	17:00	0	0	0
08:05	0	0	5	17:05	0	0	0
08:10	0	0	0	17:10	0	0	2
08:15	0	0	14	17:15	0	0	0
08:20	0	0	7	17:20	0	0	0
08:25	0	0	4	17:25	0	9*	0
08:30	0	0	0	17:30	0	0	0
08:35	0	0	1	17:35	0	0	0
08:40	0	0	0	17:40	0	0	0
08:45	0	0	0	17:45	0	0	0
08:50	0	0	4	17:50	0	0	0
08:55	0	1	1	17:55	0	0	0
09:00	0	0	0	18:00	0	0	0
09:05	0	0	0	18:05	0	0	0
09:10	0	2	1	18:10	0	0	0
09:15	0	0	1	18:15	0	0	0
09:20	0	0	0	18:20	0	0	0
09:25	0	0	0	18:25	0	0	0
09:30	0	0	0	18:30	0	0	1
09:35	0	0	0	18:35	0	0	0
09:40	0	0	0	18:40	0	0	0
09:45	0	0	0	18:45	0	0	0
09:50	0	0	0	18:50	0	0	0
09:55	0	0	0	18:55	0	0	1
10:00	0	0	0	19:00	0	0	0



Technical Note

APPENDIX B - JUNCTIONS 9 OUTPUT FILES

Junctions 9

PICADY 9 - Priority Intersection Module

Version: 9.0.1.4646 []
© Copyright TRL Limited, 2017

For sales and distribution information, program advice and maintenance, contact TRL:
Tel: +44 (0)1344 770758 email: software@trl.co.uk Web: <http://www.trlsoftware.co.uk>

The users of this computer program for the solution of an engineering problem are in no way relieved of their responsibility for the correctness of the solution

Filename: Staggered Crossroads.j9

Path: \\SERVER-01\Company\General\Projects\T17556 Graveley PC\Junction Assessments\Picady

Report generation date: 03/11/2017 12:53:44

-
- »2017, AM
 - »2017, PM
 - »2031, AM
 - »2031, PM
 - »2017 + Allocation, AM
 - »2017 + Allocation, PM
 - »2017 + Allocation + Improvements, AM
 - »2017 + Allocation + Improvements, PM
 - »10% reduction, AM

Summary of junction performance

	AM							PM						
	Queue (PCU)	Delay (s)	RFC	LOS	Junction Delay (s)	Junction LOS	Network Residual Capacity	Queue (PCU)	Delay (s)	RFC	LOS	Junction Delay (s)	Junction LOS	Network Residual Capacity
2017														
Stream B-ACD	2.5	87.67	0.75	F	2.82	A	-12 % [Stream B-ACD]	0.1	9.70	0.08	A	0.37	A	81 % [Stream D-C]
Stream AB-CD	0.0	6.05	0.04	A				0.0	6.12	0.02	A			
Stream D-AB	0.1	8.01	0.06	A				0.0	8.13	0.02	A			
Stream D-C	0.2	23.12	0.15	C				0.1	12.73	0.05	B			
Stream CD-AB	0.0	10.90	0.02	B				0.0	6.80	0.04	A			
2031														
Stream B-ACD	37.2	1660.91	2.09	F	48.33	E	-27 % [Stream B-ACD]	0.1	10.93	0.11	B	0.42	A	55 % [Stream D-C]
Stream AB-CD	0.1	6.44	0.05	A				0.0	6.45	0.03	A			
Stream D-AB	0.1	9.06	0.08	A				0.0	8.63	0.03	A			
Stream D-C	0.4	40.69	0.27	E				0.1	14.67	0.07	B			
Stream CD-AB	0.0	13.29	0.03	B				0.1	7.04	0.05	A			
2017 + Allocation														
Stream B-ACD	38.7	738.70	1.62	F	31.11	D	-26 % [Stream B-ACD]	0.2	11.51	0.17	B	0.60	A	52 % [Stream D-C]
Stream AB-CD	0.0	6.40	0.04	A				0.0	6.56	0.02	A			
Stream D-AB	0.1	8.68	0.06	A				0.0	8.73	0.03	A			
Stream D-C	0.3	34.47	0.21	D				0.1	14.98	0.06	B			
Stream CD-AB	0.1	11.36	0.09	B				0.2	6.98	0.12	A			
2017 + Allocation + Improvements														
Stream B-ACD	3.5	72.71	0.81	F	4.08	A	-10 % [Stream B-ACD]	0.2	10.11	0.15	B	0.62	A	67 % [Stream D-C]
Stream AB-CD	0.0	6.40	0.04	A				0.0	6.56	0.02	A			
Stream D-AB	0.1	8.44	0.06	A				0.0	8.72	0.03	A			
Stream D-C	0.2	21.63	0.14	C				0.1	13.63	0.06	B			
Stream CD-AB	0.1	8.76	0.07	A				0.1	6.52	0.11	A			
10% reduction														
Stream B-ACD	20.0	369.42	1.20	F	16.76	C	-21 % [Stream B-ACD]							
Stream AB-CD	0.0	6.40	0.04	A										
Stream D-AB	0.1	8.57	0.06	A										
Stream D-C	0.2	28.62	0.18	D										
Stream CD-AB	0.1	10.36	0.08	B										

There are warnings associated with one or more model runs - see the 'Data Errors and Warnings' tables for each Analysis or Demand Set.

Values shown are the highest values encountered over all time segments. Delay is the maximum value of average delay per arriving vehicle. Junction LOS and Junction Delay are demand-weighted averages. Network Residual Capacity indicates the amount by which network flow could be increased before a user-definable threshold (see Analysis Options) is met.

File summary

File Description

Title	High Street Staggered Junction
Location	Graveley
Site number	
Date	24/10/2017
Version	
Status	(new file)
Identifier	
Client	Graveley Parish
Jobnumber	T17556
Enumerator	PTBTRANSPORT\lianne.brook
Description	

Units

Distance units	Speed units	Traffic units input	Traffic units results	Flow units	Average delay units	Total delay units	Rate of delay units
m	kph	PCU	PCU	perHour	s	-Min	perMin

Analysis Options

Calculate Queue Percentiles	Calculate residual capacity	Residual capacity criteria type	RFC Threshold	Average Delay threshold (s)	Queue threshold (PCU)
	✓	Delay	0.85	36.00	20.00

Demand Set Summary

ID	Scenario name	Time Period name	Traffic profile type	Start time (HH:mm)	Finish time (HH:mm)	Time segment length (min)
D1	2017	AM	ONE HOUR	07:30	09:00	15
D2	2017	PM	ONE HOUR	16:45	18:15	15
D3	2031	AM	ONE HOUR	07:30	09:00	15
D4	2031	PM	ONE HOUR	16:45	18:15	15
D5	2017 + Allocation	AM	ONE HOUR	07:30	09:00	15
D6	2017 + Allocation	PM	ONE HOUR	16:45	18:15	15
D7	2017 + Allocation + Improvements	AM	ONE HOUR	07:30	09:00	15
D8	2017 + Allocation + Improvements	PM	ONE HOUR	16:45	18:15	15
D9	10% reduction	AM	ONE HOUR	07:30	09:00	15

Analysis Set Details

ID	Network flow scaling factor (%)
A1	100.000

2017, AM

Data Errors and Warnings

Severity	Area	Item	Description
Warning	Minor arm flare	Arm D - Minor arm geometry	Is flare very short? Estimated flare length is zero but has been increased to 1 because a zero flare length is not allowed.
Warning	Vehicle Mix		HV% is zero for all movements / time segments. Vehicle Mix matrix should be completed whether working in PCUs or Vehs.

Junction Network

Junctions

Junction	Name	Junction Type	Major road direction	Junction Delay (s)	Junction LOS
1	High Street Junctions	Left-Right Stagger	Two-way	2.82	A

Junction Network Options

Driving side	Lighting	Network residual capacity (%)	First arm reaching threshold
Left	Normal/unknown	-12	Stream B-ACD

Arms

Arms

Arm	Name	Description	Arm type
A	High Street North		Major
B	Church Lane		Minor
C	High Street South		Major
D	Oak Lane		Minor

Major Arm Geometry

Arm	Width of carriageway (m)	Has kerbed central reserve	Has right turn bay	Width for right turn (m)	Visibility for right turn (m)	Blocks?	Blocking queue (PCU)
A	6.39		✓	3.00	240.0	✓	4.00
C	6.39				150.0	✓	1.00

Geometries for Arm C are measured opposite Arm B. Geometries for Arm A (if relevant) are measured opposite Arm D.

Minor Arm Geometry

Arm	Minor arm type	Lane width (m)	Width at give-way (m)	Width at 5m (m)	Width at 10m (m)	Width at 15m (m)	Width at 20m (m)	Estimate flare length	Flare length (PCU)	Visibility to left (m)	Visibility to right (m)
B	One lane	3.20								25	30
D	One lane plus flare		5.00	4.30	3.60	3.40	3.40	✓	1.00	45	38

Slope / Intercept / Capacity

Priority Intersection Slopes and Intercepts

Junction	Stream	Intercept (PCU/hr)	Slope for AB	Slope for AC	Slope for AD	Slope for B-C	Slope for B-D	Slope for C-A	Slope for C-B	Slope for C-D	Slope for D-A	Slope for D-B
1	AB-D	775	-	-	-	-	-	0.295	0.295	0.295	-	-
1	B-A	510	0.091	0.231	0.231	-	-	0.145	0.330	-	0.145	0.330
1	B-CD	656	0.099	0.250	0.250	-	-	-	-	-	-	-
1	CD-B	661	0.252	0.252	0.252	-	-	-	-	-	-	-
1	D-AB	619	-	-	-	-	-	0.236	0.236	0.093	-	-
1	D-C	483	-	0.137	0.312	0.137	0.312	0.219	0.219	0.086	-	-

The slopes and intercepts shown above do NOT include any corrections or adjustments.
Streams may be combined, in which case capacity will be adjusted.
Values are shown for the first time segment only; they may differ for subsequent time segments.

Traffic Demand

Demand Set Details

ID	Scenario name	Time Period name	Traffic profile type	Start time (HH:mm)	Finish time (HH:mm)	Time segment length (min)
D1	2017	AM	ONE HOUR	07:30	09:00	15

Vehicle mix source	PCU Factor for a HV (PCU)
HV Percentages	2.00

Demand overview (Traffic)

Arm	Linked arm	Use O-D data	Average Demand (PCU/hr)	Scaling Factor (%)
A		✓	1208	100.000
B		✓	102	100.000
C		✓	473	100.000
D		✓	51	100.000

Origin-Destination Data

Demand (PCU/hr)

		To			
		A	B	C	D
From	A	0	11	1173	24
	B	77	0	25	0
	C	440	7	0	26
	D	26	0	25	0

Vehicle Mix

Heavy Vehicle Percentages

		To			
		A	B	C	D
From	A	0	0	0	0
	B	0	0	0	0
	C	0	0	0	0
	D	0	0	0	0

Results

Results Summary for whole modelled period

Stream	Max RFC	Max delay (s)	Max Queue (PCU)	Max LOS
B-ACD	0.75	87.67	2.5	F
A-B				
A-C				
A-D				
AB-CD	0.04	6.05	0.0	A
AB-C				
D-AB	0.06	8.01	0.1	A
D-C	0.15	23.12	0.2	C
C-D				
C-A				
C-B				
CD-AB	0.02	10.90	0.0	B
CD-A				

Main Results for each time segment

07:30 - 07:45

Stream	Total Demand (PCU/hr)	Capacity (PCU/hr)	RFC	Throughput (PCU/hr)	End queue (PCU)	Delay (s)	LOS
B-ACD	77	277	0.277	75	0.4	17.685	C
A-B	8			8			
A-C	883			883			
A-D	18			18			
AB-CD	18	670	0.027	18	0.0	5.522	A
AB-C	902			902			
D-AB	20	528	0.037	19	0.0	7.073	A
D-C	19	278	0.068	19	0.1	13.862	B
C-D	20			20			
C-A	331			331			
C-B	5			5			
CD-AB	5	436	0.012	5	0.0	8.353	A
CD-A	351			351			

07:45 - 08:00

Stream	Total Demand (PCU/hr)	Capacity (PCU/hr)	RFC	Throughput (PCU/hr)	End queue (PCU)	Delay (s)	LOS
B-ACD	92	225	0.408	91	0.7	26.583	D
A-B	10			10			
A-C	1055			1055			
A-D	22			22			
AB-CD	22	650	0.033	22	0.0	5.732	A
AB-C	1077			1077			
D-AB	23	508	0.046	23	0.0	7.420	A
D-C	22	238	0.094	22	0.1	16.666	C
C-D	23			23			
C-A	396			396			
C-B	6			6			
CD-AB	6	394	0.016	6	0.0	9.280	A
CD-A	419			419			

08:00 - 08:15

Stream	Total Demand (PCU/hr)	Capacity (PCU/hr)	RFC	Throughput (PCU/hr)	End queue (PCU)	Delay (s)	LOS
B-ACD	112	150	0.748	106	2.2	73.457	F
A-B	12			12			
A-C	1291			1291			
A-D	26			26			
AB-CD	26	621	0.043	26	0.0	6.051	A
AB-C	1317			1317			
D-AB	29	479	0.060	29	0.1	7.993	A
D-C	28	183	0.150	27	0.2	23.041	C
C-D	29			29			
C-A	484			484			
C-B	8			8			
CD-AB	8	338	0.024	8	0.0	10.901	B
CD-A	513			513			

08:15 - 08:30

Stream	Total Demand (PCU/hr)	Capacity (PCU/hr)	RFC	Throughput (PCU/hr)	End queue (PCU)	Delay (s)	LOS
B-ACD	112	150	0.748	111	2.5	87.675	F
A-B	12			12			
A-C	1291			1291			
A-D	26			26			
AB-CD	26	621	0.043	26	0.0	6.051	A
AB-C	1319			1319			
D-AB	29	478	0.060	29	0.1	8.007	A
D-C	28	183	0.150	28	0.2	23.124	C
C-D	29			29			
C-A	484			484			
C-B	8			8			
CD-AB	8	338	0.024	8	0.0	10.904	B
CD-A	513			513			

08:30 - 08:45

Stream	Total Demand (PCU/hr)	Capacity (PCU/hr)	RFC	Throughput (PCU/hr)	End queue (PCU)	Delay (s)	LOS
B-ACD	92	225	0.408	99	0.7	30.017	D
A-B	10			10			
A-C	1055			1055			
A-D	22			22			
AB-CD	22	650	0.033	22	0.0	5.733	A
AB-C	1079			1079			
D-AB	23	507	0.046	23	0.0	7.439	A
D-C	22	238	0.094	23	0.1	16.714	C
C-D	23			23			
C-A	396			396			
C-B	6			6			
CD-AB	6	394	0.016	6	0.0	9.283	A
CD-A	419			419			

08:45 - 09:00

Stream	Total Demand (PCU/hr)	Capacity (PCU/hr)	RFC	Throughput (PCU/hr)	End queue (PCU)	Delay (s)	LOS
B-ACD	77	277	0.277	78	0.4	18.182	C
A-B	8			8			
A-C	883			883			
A-D	18			18			
AB-CD	18	670	0.027	18	0.0	5.524	A
AB-C	902			902			
D-AB	20	527	0.037	20	0.0	7.092	A
D-C	19	278	0.068	19	0.1	13.891	B
C-D	20			20			
C-A	331			331			
C-B	5			5			
CD-AB	5	436	0.012	5	0.0	8.355	A
CD-A	351			351			

2017, PM

Data Errors and Warnings

Severity	Area	Item	Description
Warning	Minor arm flare	Arm D - Minor arm geometry	Is flare very short? Estimated flare length is zero but has been increased to 1 because a zero flare length is not allowed.
Warning	Vehicle Mix		HV% is zero for all movements / time segments. Vehicle Mix matrix should be completed whether working in PCUs or Vehs.

Junction Network

Junctions

Junction	Name	Junction Type	Major road direction	Junction Delay (s)	Junction LOS
1	High Street Junctions	Left-Right Stagger	Two-way	0.37	A

Junction Network Options

Driving side	Lighting	Network residual capacity (%)	First arm reaching threshold
Left	Normal/unknown	81	Stream D-C

Traffic Demand

Demand Set Details

ID	Scenario name	Time Period name	Traffic profile type	Start time (HH:mm)	Finish time (HH:mm)	Time segment length (min)
D2	2017	PM	ONE HOUR	16:45	18:15	15

Vehicle mix source	PCU Factor for a HV (PCU)
HV Percentages	2.00

Demand overview (Traffic)

Arm	Linked arm	Use O-D data	Average Demand (PCU/hr)	Scaling Factor (%)
A		✓	473	100.000
B		✓	31	100.000
C		✓	537	100.000
D		✓	24	100.000

Origin-Destination Data

Demand (PCU/hr)

		To			
		A	B	C	D
From	A	0	19	443	11
	B	13	0	18	0
	C	490	19	0	28
	D	10	0	14	0

Vehicle Mix

Heavy Vehicle Percentages

	To				
	A	B	C	D	
From	A	0	0	0	0
	B	0	0	0	0
	C	0	0	0	0
	D	0	0	0	0

Results

Results Summary for whole modelled period

Stream	Max RFC	Max delay (s)	Max Queue (PCU)	Max LOS
B-ACD	0.08	9.70	0.1	A
A-B				
A-C				
A-D				
AB-CD	0.02	6.12	0.0	A
AB-C				
D-AB	0.02	8.13	0.0	A
D-C	0.05	12.73	0.1	B
C-D				
C-A				
C-B				
CD-AB	0.04	6.80	0.0	A
CD-A				

Main Results for each time segment

16:45 - 17:00

Stream	Total Demand (PCU/hr)	Capacity (PCU/hr)	RFC	Throughput (PCU/hr)	End queue (PCU)	Delay (s)	LOS
B-ACD	23	465	0.050	23	0.1	8.148	A
A-B	14			14			
A-C	334			334			
A-D	8			8			
AB-CD	8	656	0.013	8	0.0	5.560	A
AB-C	347			347			
D-AB	8	497	0.015	7	0.0	7.353	A
D-C	11	364	0.029	10	0.0	10.176	B
C-D	21			21			
C-A	369			369			
C-B	14			14			
CD-AB	15	581	0.025	14	0.0	6.358	A
CD-A	376			376			

17:00 - 17:15

Stream	Total Demand (PCU/hr)	Capacity (PCU/hr)	RFC	Throughput (PCU/hr)	End queue (PCU)	Delay (s)	LOS
B-ACD	28	440	0.063	28	0.1	8.730	A
A-B	17			17			
A-C	398			398			
A-D	10			10			
AB-CD	10	633	0.016	10	0.0	5.781	A
AB-C	414			414			
D-AB	9	479	0.019	9	0.0	7.660	A
D-C	13	336	0.037	13	0.0	11.111	B
C-D	25			25			
C-A	440			440			
C-B	17			17			
CD-AB	18	568	0.031	17	0.0	6.542	A
CD-A	449			449			

17:15 - 17:30

Stream	Total Demand (PCU/hr)	Capacity (PCU/hr)	RFC	Throughput (PCU/hr)	End queue (PCU)	Delay (s)	LOS
B-ACD	34	405	0.084	34	0.1	9.698	A
A-B	21			21			
A-C	488			488			
A-D	12			12			
AB-CD	12	600	0.020	12	0.0	6.117	A
AB-C	508			508			
D-AB	11	454	0.024	11	0.0	8.129	A
D-C	15	298	0.052	15	0.1	12.723	B
C-D	31			31			
C-A	540			540			
C-B	21			21			
CD-AB	22	551	0.039	22	0.0	6.795	A
CD-A	550			550			

17:30 - 17:45

Stream	Total Demand (PCU/hr)	Capacity (PCU/hr)	RFC	Throughput (PCU/hr)	End queue (PCU)	Delay (s)	LOS
B-ACD	34	405	0.084	34	0.1	9.702	A
A-B	21			21			
A-C	488			488			
A-D	12			12			
AB-CD	12	600	0.020	12	0.0	6.117	A
AB-C	508			508			
D-AB	11	454	0.024	11	0.0	8.132	A
D-C	15	298	0.052	15	0.1	12.726	B
C-D	31			31			
C-A	540			540			
C-B	21			21			
CD-AB	22	551	0.039	22	0.0	6.798	A
CD-A	550			550			

17:45 - 18:00

Stream	Total Demand (PCU/hr)	Capacity (PCU/hr)	RFC	Throughput (PCU/hr)	End queue (PCU)	Delay (s)	LOS
B-ACD	28	440	0.063	28	0.1	8.736	A
A-B	17			17			
A-C	398			398			
A-D	10			10			
AB-CD	10	633	0.016	10	0.0	5.783	A
AB-C	414			414			
D-AB	9	479	0.019	9	0.0	7.665	A
D-C	13	337	0.037	13	0.0	11.113	B
C-D	25			25			
C-A	440			440			
C-B	17			17			
CD-AB	18	568	0.031	18	0.0	6.543	A
CD-A	449			449			

18:00 - 18:15

Stream	Total Demand (PCU/hr)	Capacity (PCU/hr)	RFC	Throughput (PCU/hr)	End queue (PCU)	Delay (s)	LOS
B-ACD	23	465	0.050	23	0.1	8.158	A
A-B	14			14			
A-C	334			334			
A-D	8			8			
AB-CD	8	656	0.013	8	0.0	5.560	A
AB-C	347			347			
D-AB	8	497	0.015	8	0.0	7.359	A
D-C	11	364	0.029	11	0.0	10.181	B
C-D	21			21			
C-A	369			369			
C-B	14			14			
CD-AB	15	581	0.025	15	0.0	6.359	A
CD-A	376			376			

2031, AM

Data Errors and Warnings

Severity	Area	Item	Description
Warning	Minor arm flare	Arm D - Minor arm geometry	Is flare very short? Estimated flare length is zero but has been increased to 1 because a zero flare length is not allowed.
Warning	Vehicle Mix		HV% is zero for all movements / time segments. Vehicle Mix matrix should be completed whether working in PCUs or Vehs.

Junction Network

Junctions

Junction	Name	Junction Type	Major road direction	Junction Delay (s)	Junction LOS
1	High Street Junctions	Left-Right Stagger	Two-way	48.33	E

Junction Network Options

Driving side	Lighting	Network residual capacity (%)	First arm reaching threshold
Left	Normal/unknown	-27	Stream B-ACD

Traffic Demand

Demand Set Details

ID	Scenario name	Time Period name	Traffic profile type	Start time (HH:mm)	Finish time (HH:mm)	Time segment length (min)
D3	2031	AM	ONE HOUR	07:30	09:00	15

Vehicle mix source	PCU Factor for a HV (PCU)
HV Percentages	2.00

Demand overview (Traffic)

Arm	Linked arm	Use O-D data	Average Demand (PCU/hr)	Scaling Factor (%)
A		✓	1448	100.000
B		✓	122	100.000
C		✓	567	100.000
D		✓	61	100.000

Origin-Destination Data

Demand (PCU/hr)

		To			
		A	B	C	D
From	A	0	13	1406	29
	B	92	0	30	0
	C	528	8	0	31
	D	31	0	30	0

Vehicle Mix

Heavy Vehicle Percentages

	To				
	A	B	C	D	
From	A	0	0	0	0
	B	0	0	0	0
	C	0	0	0	0
	D	0	0	0	0

Results

Results Summary for whole modelled period

Stream	Max RFC	Max delay (s)	Max Queue (PCU)	Max LOS
B-ACD	2.09	1660.91	37.2	F
A-B				
A-C				
A-D				
AB-CD	0.05	6.44	0.1	A
AB-C				
D-AB	0.08	9.06	0.1	A
D-C	0.27	40.69	0.4	E
C-D				
C-A				
C-B				
CD-AB	0.03	13.29	0.0	B
CD-A				

Main Results for each time segment

07:30 - 07:45

Stream	Total Demand (PCU/hr)	Capacity (PCU/hr)	RFC	Throughput (PCU/hr)	End queue (PCU)	Delay (s)	LOS
B-ACD	92	224	0.411	89	0.7	26.288	D
A-B	10			10			
A-C	1059			1059			
A-D	22			22			
AB-CD	22	649	0.034	22	0.0	5.737	A
AB-C	1080			1080			
D-AB	23	508	0.046	23	0.0	7.423	A
D-C	23	237	0.095	22	0.1	16.699	C
C-D	23			23			
C-A	398			398			
C-B	6			6			
CD-AB	6	393	0.016	6	0.0	9.303	A
CD-A	421			421			

07:45 - 08:00

Stream	Total Demand (PCU/hr)	Capacity (PCU/hr)	RFC	Throughput (PCU/hr)	End queue (PCU)	Delay (s)	LOS
B-ACD	110	159	0.690	105	1.8	62.080	F
A-B	12			12			
A-C	1264			1264			
A-D	26			26			
AB-CD	26	625	0.042	26	0.0	6.014	A
AB-C	1290			1290			
D-AB	28	482	0.058	28	0.1	7.923	A
D-C	27	190	0.142	27	0.2	22.061	C
C-D	28			28			
C-A	475			475			
C-B	7			7			
CD-AB	7	344	0.022	7	0.0	10.694	B
CD-A	502			502			

08:00 - 08:15

Stream	Total Demand (PCU/hr)	Capacity (PCU/hr)	RFC	Throughput (PCU/hr)	End queue (PCU)	Delay (s)	LOS
B-ACD	134	64	2.085	63	19.7	669.322	F
A-B	14			14			
A-C	1548			1548			
A-D	32			32			
AB-CD	32	591	0.054	32	0.1	6.441	A
AB-C	1563			1563			
D-AB	34	435	0.078	34	0.1	8.977	A
D-C	33	123	0.268	32	0.3	39.188	E
C-D	34			34			
C-A	581			581			
C-B	9			9			
CD-AB	10	280	0.034	9	0.0	13.284	B
CD-A	615			615			

08:15 - 08:30

Stream	Total Demand (PCU/hr)	Capacity (PCU/hr)	RFC	Throughput (PCU/hr)	End queue (PCU)	Delay (s)	LOS
B-ACD	134	64	2.086	64	37.2	1660.906	F
A-B	14			14			
A-C	1548			1548			
A-D	32			32			
AB-CD	32	591	0.054	32	0.1	6.441	A
AB-C	1564			1564			
D-AB	34	432	0.079	34	0.1	9.055	A
D-C	33	121	0.272	33	0.4	40.693	E
C-D	34			34			
C-A	581			581			
C-B	9			9			
CD-AB	10	280	0.034	10	0.0	13.290	B
CD-A	615			615			

08:30 - 08:45

Stream	Total Demand (PCU/hr)	Capacity (PCU/hr)	RFC	Throughput (PCU/hr)	End queue (PCU)	Delay (s)	LOS
B-ACD	110	159	0.690	155	25.9	656.776	F
A-B	12			12			
A-C	1264			1264			
A-D	26			26			
AB-CD	26	625	0.042	26	0.0	6.015	A
AB-C	1302			1302			
D-AB	28	479	0.058	28	0.1	7.988	A
D-C	27	185	0.145	28	0.2	22.921	C
C-D	28			28			
C-A	475			475			
C-B	7			7			
CD-AB	7	344	0.022	7	0.0	10.698	B
CD-A	502			502			

08:45 - 09:00

Stream	Total Demand (PCU/hr)	Capacity (PCU/hr)	RFC	Throughput (PCU/hr)	End queue (PCU)	Delay (s)	LOS
B-ACD	92	224	0.411	192	0.8	203.774	F
A-B	10			10			
A-C	1059			1059			
A-D	22			22			
AB-CD	22	649	0.034	22	0.0	5.742	A
AB-C	1106			1106			
D-AB	23	506	0.046	23	0.0	7.459	A
D-C	23	234	0.096	23	0.1	17.037	C
C-D	23			23			
C-A	398			398			
C-B	6			6			
CD-AB	6	393	0.016	6	0.0	9.306	A
CD-A	421			421			

2031, PM

Data Errors and Warnings

Severity	Area	Item	Description
Warning	Minor arm flare	Arm D - Minor arm geometry	Is flare very short? Estimated flare length is zero but has been increased to 1 because a zero flare length is not allowed.
Warning	Vehicle Mix		HV% is zero for all movements / time segments. Vehicle Mix matrix should be completed whether working in PCUs or Vehs.

Junction Network

Junctions

Junction	Name	Junction Type	Major road direction	Junction Delay (s)	Junction LOS
1	High Street Junctions	Left-Right Stagger	Two-way	0.42	A

Junction Network Options

Driving side	Lighting	Network residual capacity (%)	First arm reaching threshold
Left	Normal/unknown	55	Stream D-C

Traffic Demand

Demand Set Details

ID	Scenario name	Time Period name	Traffic profile type	Start time (HH:mm)	Finish time (HH:mm)	Time segment length (min)
D4	2031	PM	ONE HOUR	16:45	18:15	15

Vehicle mix source	PCU Factor for a HV (PCU)
HV Percentages	2.00

Demand overview (Traffic)

Arm	Linked arm	Use O-D data	Average Demand (PCU/hr)	Scaling Factor (%)
A		✓	556	100.000
B		✓	38	100.000
C		✓	624	100.000
D		✓	29	100.000

Origin-Destination Data

Demand (PCU/hr)

		To			
		A	B	C	D
From	A	0	23	520	13
	B	16	0	22	0
	C	567	23	0	34
	D	12	0	17	0

Vehicle Mix

Heavy Vehicle Percentages

	To				
	A	B	C	D	
From	A	0	0	0	0
	B	0	0	0	0
	C	0	0	0	0
	D	0	0	0	0

Results

Results Summary for whole modelled period

Stream	Max RFC	Max delay (s)	Max Queue (PCU)	Max LOS
B-ACD	0.11	10.93	0.1	B
A-B				
A-C				
A-D				
AB-CD	0.03	6.45	0.0	A
AB-C				
D-AB	0.03	8.63	0.0	A
D-C	0.07	14.67	0.1	B
C-D				
C-A				
C-B				
CD-AB	0.05	7.04	0.1	A
CD-A				

Main Results for each time segment

16:45 - 17:00

Stream	Total Demand (PCU/hr)	Capacity (PCU/hr)	RFC	Throughput (PCU/hr)	End queue (PCU)	Delay (s)	LOS
B-ACD	29	443	0.065	28	0.1	8.681	A
A-B	17			17			
A-C	391			391			
A-D	10			10			
AB-CD	10	636	0.015	10	0.0	5.745	A
AB-C	408			408			
D-AB	9	481	0.019	9	0.0	7.622	A
D-C	13	341	0.038	13	0.0	10.963	B
C-D	26			26			
C-A	427			427			
C-B	17			17			
CD-AB	18	569	0.031	18	0.0	6.526	A
CD-A	435			435			

17:00 - 17:15

Stream	Total Demand (PCU/hr)	Capacity (PCU/hr)	RFC	Throughput (PCU/hr)	End queue (PCU)	Delay (s)	LOS
B-ACD	34	413	0.083	34	0.1	9.490	A
A-B	21			21			
A-C	467			467			
A-D	12			12			
AB-CD	12	609	0.019	12	0.0	6.021	A
AB-C	487			487			
D-AB	11	460	0.023	11	0.0	8.013	A
D-C	15	309	0.050	15	0.1	12.268	B
C-D	31			31			
C-A	510			510			
C-B	21			21			
CD-AB	21	555	0.039	21	0.0	6.744	A
CD-A	520			520			

17:15 - 17:30

Stream	Total Demand (PCU/hr)	Capacity (PCU/hr)	RFC	Throughput (PCU/hr)	End queue (PCU)	Delay (s)	LOS
B-ACD	42	371	0.113	42	0.1	10.919	B
A-B	25			25			
A-C	573			573			
A-D	14			14			
AB-CD	14	572	0.025	14	0.0	6.451	A
AB-C	597			597			
D-AB	13	431	0.031	13	0.0	8.625	A
D-C	19	264	0.071	19	0.1	14.662	B
C-D	37			37			
C-A	624			624			
C-B	25			25			
CD-AB	27	539	0.050	27	0.1	7.034	A
CD-A	636			636			

17:30 - 17:45

Stream	Total Demand (PCU/hr)	Capacity (PCU/hr)	RFC	Throughput (PCU/hr)	End queue (PCU)	Delay (s)	LOS
B-ACD	42	371	0.113	42	0.1	10.928	B
A-B	25			25			
A-C	573			573			
A-D	14			14			
AB-CD	14	572	0.025	14	0.0	6.451	A
AB-C	597			597			
D-AB	13	430	0.031	13	0.0	8.629	A
D-C	19	264	0.071	19	0.1	14.674	B
C-D	37			37			
C-A	624			624			
C-B	25			25			
CD-AB	27	539	0.050	27	0.1	7.037	A
CD-A	636			636			

17:45 - 18:00

Stream	Total Demand (PCU/hr)	Capacity (PCU/hr)	RFC	Throughput (PCU/hr)	End queue (PCU)	Delay (s)	LOS
B-ACD	34	413	0.083	34	0.1	9.501	A
A-B	21			21			
A-C	467			467			
A-D	12			12			
AB-CD	12	609	0.019	12	0.0	6.024	A
AB-C	487			487			
D-AB	11	460	0.023	11	0.0	8.022	A
D-C	15	309	0.049	15	0.1	12.274	B
C-D	31			31			
C-A	510			510			
C-B	21			21			
CD-AB	21	555	0.039	22	0.0	6.748	A
CD-A	520			520			

18:00 - 18:15

Stream	Total Demand (PCU/hr)	Capacity (PCU/hr)	RFC	Throughput (PCU/hr)	End queue (PCU)	Delay (s)	LOS
B-ACD	29	443	0.065	29	0.1	8.696	A
A-B	17			17			
A-C	391			391			
A-D	10			10			
AB-CD	10	636	0.015	10	0.0	5.745	A
AB-C	408			408			
D-AB	9	481	0.019	9	0.0	7.630	A
D-C	13	341	0.038	13	0.0	10.969	B
C-D	26			26			
C-A	427			427			
C-B	17			17			
CD-AB	18	569	0.031	18	0.0	6.532	A
CD-A	435			435			

2017 + Allocation, AM

Data Errors and Warnings

Severity	Area	Item	Description
Warning	Minor arm flare	Arm D - Minor arm geometry	Is flare very short? Estimated flare length is zero but has been increased to 1 because a zero flare length is not allowed.
Warning	Vehicle Mix		HV% is zero for all movements / time segments. Vehicle Mix matrix should be completed whether working in PCUs or Vehs.

Junction Network

Junctions

Junction	Name	Junction Type	Major road direction	Junction Delay (s)	Junction LOS
1	High Street Junctions	Left-Right Stagger	Two-way	31.11	D

Junction Network Options

Driving side	Lighting	Network residual capacity (%)	First arm reaching threshold
Left	Normal/unknown	-26	Stream B-ACD

Traffic Demand

Demand Set Details

ID	Scenario name	Time Period name	Traffic profile type	Start time (HH:mm)	Finish time (HH:mm)	Time segment length (min)
D5	2017 + Allocation	AM	ONE HOUR	07:30	09:00	15

Vehicle mix source	PCU Factor for a HV (PCU)
HV Percentages	2.00

Demand overview (Traffic)

Arm	Linked arm	Use O-D data	Average Demand (PCU/hr)	Scaling Factor (%)
A		✓	1324	100.000
B		✓	169	100.000
C		✓	572	100.000
D		✓	51	100.000

Origin-Destination Data

Demand (PCU/hr)

		To			
		A	B	C	D
From	A	0	19	1281	24
	B	99	0	70	0
	C	522	24	0	26
	D	26	0	25	0

Vehicle Mix

Heavy Vehicle Percentages

	To				
	A	B	C	D	
From	A	0	0	0	0
	B	0	0	0	0
	C	0	0	0	0
	D	0	0	0	0

Results

Results Summary for whole modelled period

Stream	Max RFC	Max delay (s)	Max Queue (PCU)	Max LOS
B-ACD	1.62	738.70	38.7	F
A-B				
A-C				
A-D				
AB-CD	0.04	6.40	0.0	A
AB-C				
D-AB	0.06	8.68	0.1	A
D-C	0.21	34.47	0.3	D
C-D				
C-A				
C-B				
CD-AB	0.09	11.36	0.1	B
CD-A				

Main Results for each time segment

07:30 - 07:45

Stream	Total Demand (PCU/hr)	Capacity (PCU/hr)	RFC	Throughput (PCU/hr)	End queue (PCU)	Delay (s)	LOS
B-ACD	127	269	0.474	124	0.9	24.326	C
A-B	14			14			
A-C	964			964			
A-D	18			18			
AB-CD	18	648	0.028	18	0.0	5.715	A
AB-C	1016			1016			
D-AB	20	510	0.038	19	0.0	7.340	A
D-C	19	246	0.077	18	0.1	15.815	C
C-D	20			20			
C-A	393			393			
C-B	18			18			
CD-AB	19	428	0.044	19	0.0	8.789	A
CD-A	412			412			

07:45 - 08:00

Stream	Total Demand (PCU/hr)	Capacity (PCU/hr)	RFC	Throughput (PCU/hr)	End queue (PCU)	Delay (s)	LOS
B-ACD	152	207	0.734	146	2.3	54.918	F
A-B	17			17			
A-C	1152			1152			
A-D	22			22			
AB-CD	22	623	0.035	22	0.0	5.982	A
AB-C	1212			1212			
D-AB	23	485	0.048	23	0.1	7.792	A
D-C	22	200	0.113	22	0.1	20.268	C
C-D	23			23			
C-A	469			469			
C-B	22			22			
CD-AB	23	391	0.060	23	0.1	9.797	A
CD-A	491			491			

08:00 - 08:15

Stream	Total Demand (PCU/hr)	Capacity (PCU/hr)	RFC	Throughput (PCU/hr)	End queue (PCU)	Delay (s)	LOS
B-ACD	186	115	1.622	112	20.8	416.245	F
A-B	21			21			
A-C	1410			1410			
A-D	26			26			
AB-CD	26	589	0.045	26	0.0	6.396	A
AB-C	1457			1457			
D-AB	29	446	0.064	29	0.1	8.628	A
D-C	28	136	0.203	27	0.2	32.958	D
C-D	29			29			
C-A	575			575			
C-B	26			26			
CD-AB	31	348	0.090	31	0.1	11.357	B
CD-A	598			598			

08:15 - 08:30

Stream	Total Demand (PCU/hr)	Capacity (PCU/hr)	RFC	Throughput (PCU/hr)	End queue (PCU)	Delay (s)	LOS
B-ACD	186	115	1.623	114	38.7	738.697	F
A-B	21			21			
A-C	1410			1410			
A-D	26			26			
AB-CD	26	589	0.045	26	0.0	6.396	A
AB-C	1458			1458			
D-AB	29	443	0.065	29	0.1	8.682	A
D-C	28	132	0.209	27	0.3	34.472	D
C-D	29			29			
C-A	575			575			
C-B	26			26			
CD-AB	31	348	0.090	31	0.1	11.365	B
CD-A	598			598			

08:30 - 08:45

Stream	Total Demand (PCU/hr)	Capacity (PCU/hr)	RFC	Throughput (PCU/hr)	End queue (PCU)	Delay (s)	LOS
B-ACD	152	207	0.734	202	26.3	547.237	F
A-B	17			17			
A-C	1152			1152			
A-D	22			22			
AB-CD	22	623	0.035	22	0.0	5.985	A
AB-C	1235			1235			
D-AB	23	483	0.048	23	0.1	7.843	A
D-C	22	192	0.117	23	0.1	21.383	C
C-D	23			23			
C-A	469			469			
C-B	22			22			
CD-AB	23	391	0.060	24	0.1	9.810	A
CD-A	491			491			

08:45 - 09:00

Stream	Total Demand (PCU/hr)	Capacity (PCU/hr)	RFC	Throughput (PCU/hr)	End queue (PCU)	Delay (s)	LOS
B-ACD	127	269	0.474	228	1.0	165.171	F
A-B	14			14			
A-C	964			964			
A-D	18			18			
AB-CD	18	648	0.028	18	0.0	5.715	A
AB-C	1059			1059			
D-AB	20	508	0.039	20	0.0	7.370	A
D-C	19	240	0.078	19	0.1	16.277	C
C-D	20			20			
C-A	393			393			
C-B	18			18			
CD-AB	19	428	0.044	19	0.0	8.799	A
CD-A	412			412			

2017 + Allocation, PM

Data Errors and Warnings

Severity	Area	Item	Description
Warning	Minor arm flare	Arm D - Minor arm geometry	Is flare very short? Estimated flare length is zero but has been increased to 1 because a zero flare length is not allowed.
Warning	Vehicle Mix		HV% is zero for all movements / time segments. Vehicle Mix matrix should be completed whether working in PCUs or Vehs.

Junction Network

Junctions

Junction	Name	Junction Type	Major road direction	Junction Delay (s)	Junction LOS
1	High Street Junctions	Left-Right Stagger	Two-way	0.60	A

Junction Network Options

Driving side	Lighting	Network residual capacity (%)	First arm reaching threshold
Left	Normal/unknown	52	Stream D-C

Traffic Demand

Demand Set Details

ID	Scenario name	Time Period name	Traffic profile type	Start time (HH:mm)	Finish time (HH:mm)	Time segment length (min)
D6	2017 + Allocation	PM	ONE HOUR	16:45	18:15	15

Vehicle mix source	PCU Factor for a HV (PCU)
HV Percentages	2.00

Demand overview (Traffic)

Arm	Linked arm	Use O-D data	Average Demand (PCU/hr)	Scaling Factor (%)
A		✓	549	100.000
B		✓	59	100.000
C		✓	658	100.000
D		✓	24	100.000

Origin-Destination Data

Demand (PCU/hr)

		To			
		A	B	C	D
From	A	0	38	500	11
	B	22	0	37	0
	C	574	56	0	28
	D	10	0	14	0

Vehicle Mix

Heavy Vehicle Percentages

	To				
	A	B	C	D	
From	A	0	0	0	0
	B	0	0	0	0
	C	0	0	0	0
	D	0	0	0	0

Results

Results Summary for whole modelled period

Stream	Max RFC	Max delay (s)	Max Queue (PCU)	Max LOS
B-ACD	0.17	11.51	0.2	B
A-B				
A-C				
A-D				
AB-CD	0.02	6.56	0.0	A
AB-C				
D-AB	0.03	8.73	0.0	A
D-C	0.06	14.98	0.1	B
C-D				
C-A				
C-B				
CD-AB	0.12	6.98	0.2	A
CD-A				

Main Results for each time segment

16:45 - 17:00

Stream	Total Demand (PCU/hr)	Capacity (PCU/hr)	RFC	Throughput (PCU/hr)	End queue (PCU)	Delay (s)	LOS
B-ACD	44	451	0.099	44	0.1	8.845	A
A-B	29			29			
A-C	376			376			
A-D	8			8			
AB-CD	8	629	0.013	8	0.0	5.801	A
AB-C	404			404			
D-AB	8	476	0.016	7	0.0	7.676	A
D-C	11	335	0.031	10	0.0	11.093	B
C-D	21			21			
C-A	432			432			
C-B	42			42			
CD-AB	45	590	0.076	44	0.1	6.592	A
CD-A	437			437			

17:00 - 17:15

Stream	Total Demand (PCU/hr)	Capacity (PCU/hr)	RFC	Throughput (PCU/hr)	End queue (PCU)	Delay (s)	LOS
B-ACD	53	421	0.126	53	0.1	9.785	A
A-B	34			34			
A-C	449			449			
A-D	10			10			
AB-CD	10	600	0.016	10	0.0	6.095	A
AB-C	483			483			
D-AB	9	454	0.020	9	0.0	8.086	A
D-C	13	302	0.042	13	0.0	12.449	B
C-D	25			25			
C-A	516			516			
C-B	50			50			
CD-AB	55	586	0.094	55	0.1	6.780	A
CD-A	520			520			

17:15 - 17:30

Stream	Total Demand (PCU/hr)	Capacity (PCU/hr)	RFC	Throughput (PCU/hr)	End queue (PCU)	Delay (s)	LOS
B-ACD	65	378	0.172	65	0.2	11.486	B
A-B	42			42			
A-C	551			551			
A-D	12			12			
AB-CD	12	561	0.022	12	0.0	6.555	A
AB-C	591			591			
D-AB	11	423	0.026	11	0.0	8.730	A
D-C	15	256	0.060	15	0.1	14.979	B
C-D	31			31			
C-A	632			632			
C-B	62			62			
CD-AB	71	587	0.121	71	0.2	6.979	A
CD-A	634			634			

17:30 - 17:45

Stream	Total Demand (PCU/hr)	Capacity (PCU/hr)	RFC	Throughput (PCU/hr)	End queue (PCU)	Delay (s)	LOS
B-ACD	65	378	0.172	65	0.2	11.506	B
A-B	42			42			
A-C	551			551			
A-D	12			12			
AB-CD	12	561	0.022	12	0.0	6.555	A
AB-C	591			591			
D-AB	11	423	0.026	11	0.0	8.734	A
D-C	15	256	0.060	15	0.1	14.984	B
C-D	31			31			
C-A	632			632			
C-B	62			62			
CD-AB	71	587	0.121	71	0.2	6.984	A
CD-A	634			634			

17:45 - 18:00

Stream	Total Demand (PCU/hr)	Capacity (PCU/hr)	RFC	Throughput (PCU/hr)	End queue (PCU)	Delay (s)	LOS
B-ACD	53	421	0.126	53	0.1	9.803	A
A-B	34			34			
A-C	449			449			
A-D	10			10			
AB-CD	10	600	0.016	10	0.0	6.098	A
AB-C	483			483			
D-AB	9	454	0.020	9	0.0	8.093	A
D-C	13	302	0.042	13	0.0	12.455	B
C-D	25			25			
C-A	516			516			
C-B	50			50			
CD-AB	55	586	0.094	55	0.1	6.785	A
CD-A	520			520			

18:00 - 18:15

Stream	Total Demand (PCU/hr)	Capacity (PCU/hr)	RFC	Throughput (PCU/hr)	End queue (PCU)	Delay (s)	LOS
B-ACD	44	450	0.099	45	0.1	8.871	A
A-B	29			29			
A-C	376			376			
A-D	8			8			
AB-CD	8	629	0.013	8	0.0	5.801	A
AB-C	404			404			
D-AB	8	476	0.016	8	0.0	7.684	A
D-C	11	335	0.031	11	0.0	11.094	B
C-D	21			21			
C-A	432			432			
C-B	42			42			
CD-AB	45	590	0.076	45	0.1	6.602	A
CD-A	437			437			

2017 + Allocation + Improvements, AM

Data Errors and Warnings

Severity	Area	Item	Description
Warning	Minor arm flare	Arm D - Minor arm geometry	Is flare very short? Estimated flare length is zero but has been increased to 1 because a zero flare length is not allowed.
Warning	Vehicle Mix		HV% is zero for all movements / time segments. Vehicle Mix matrix should be completed whether working in PCUs or Vehs.

Junction Network

Junctions

Junction	Name	Junction Type	Major road direction	Junction Delay (s)	Junction LOS
1	High Street Junctions	Left-Right Stagger	Two-way	4.08	A

Junction Network Options

Driving side	Lighting	Network residual capacity (%)	First arm reaching threshold
Left	Normal/unknown	-10	Stream B-ACD

Traffic Demand

Demand Set Details

ID	Scenario name	Time Period name	Traffic profile type	Start time (HH:mm)	Finish time (HH:mm)	Time segment length (min)
D7	2017 + Allocation + Improvements	AM	ONE HOUR	07:30	09:00	15

Vehicle mix source	PCU Factor for a HV (PCU)
HV Percentages	2.00

Demand overview (Traffic)

Arm	Linked arm	Use O-D data	Average Demand (PCU/hr)	Scaling Factor (%)
A		✓	940	100.000
B		✓	169	100.000
C		✓	572	100.000
D		✓	51	100.000

Origin-Destination Data

Demand (PCU/hr)

		To			
		A	B	C	D
From	A	0	19	897	24
	B	99	0	70	0
	C	522	24	0	26
	D	26	0	25	0

Vehicle Mix

Heavy Vehicle Percentages

	To				
	A	B	C	D	
From	A	0	0	0	0
	B	0	0	0	0
	C	0	0	0	0
	D	0	0	0	0

Results

Results Summary for whole modelled period

Stream	Max RFC	Max delay (s)	Max Queue (PCU)	Max LOS
B-ACD	0.81	72.71	3.5	F
A-B				
A-C				
A-D				
AB-CD	0.04	6.40	0.0	A
AB-C				
D-AB	0.06	8.44	0.1	A
D-C	0.14	21.63	0.2	C
C-D				
C-A				
C-B				
CD-AB	0.07	8.76	0.1	A
CD-A				

Main Results for each time segment

07:30 - 07:45

Stream	Total Demand (PCU/hr)	Capacity (PCU/hr)	RFC	Throughput (PCU/hr)	End queue (PCU)	Delay (s)	LOS
B-ACD	127	341	0.373	125	0.6	16.476	C
A-B	14			14			
A-C	675			675			
A-D	18			18			
AB-CD	18	648	0.028	18	0.0	5.715	A
AB-C	727			727			
D-AB	20	511	0.038	19	0.0	7.318	A
D-C	19	286	0.066	19	0.1	13.468	B
C-D	20			20			
C-A	393			393			
C-B	18			18			
CD-AB	19	498	0.037	18	0.0	7.503	A
CD-A	412			412			

07:45 - 08:00

Stream	Total Demand (PCU/hr)	Capacity (PCU/hr)	RFC	Throughput (PCU/hr)	End queue (PCU)	Delay (s)	LOS
B-ACD	152	296	0.513	150	1.0	24.413	C
A-B	17			17			
A-C	806			806			
A-D	22			22			
AB-CD	22	623	0.035	22	0.0	5.982	A
AB-C	869			869			
D-AB	23	489	0.048	23	0.0	7.738	A
D-C	22	247	0.091	22	0.1	15.998	C
C-D	23			23			
C-A	469			469			
C-B	22			22			
CD-AB	23	472	0.048	23	0.1	8.015	A
CD-A	491			491			

08:00 - 08:15

Stream	Total Demand (PCU/hr)	Capacity (PCU/hr)	RFC	Throughput (PCU/hr)	End queue (PCU)	Delay (s)	LOS
B-ACD	186	231	0.806	178	3.1	60.213	F
A-B	21			21			
A-C	988			988			
A-D	26			26			
AB-CD	26	589	0.045	26	0.0	6.397	A
AB-C	1061			1061			
D-AB	29	456	0.063	29	0.1	8.429	A
D-C	28	194	0.142	27	0.2	21.533	C
C-D	29			29			
C-A	575			575			
C-B	26			26			
CD-AB	29	440	0.066	29	0.1	8.754	A
CD-A	601			601			

08:15 - 08:30

Stream	Total Demand (PCU/hr)	Capacity (PCU/hr)	RFC	Throughput (PCU/hr)	End queue (PCU)	Delay (s)	LOS
B-ACD	186	231	0.806	185	3.5	72.713	F
A-B	21			21			
A-C	988			988			
A-D	26			26			
AB-CD	26	589	0.045	26	0.0	6.397	A
AB-C	1064			1064			
D-AB	29	455	0.063	29	0.1	8.442	A
D-C	28	194	0.142	28	0.2	21.635	C
C-D	29			29			
C-A	575			575			
C-B	26			26			
CD-AB	29	440	0.066	29	0.1	8.759	A
CD-A	601			601			

08:30 - 08:45

Stream	Total Demand (PCU/hr)	Capacity (PCU/hr)	RFC	Throughput (PCU/hr)	End queue (PCU)	Delay (s)	LOS
B-ACD	152	296	0.513	161	1.1	28.382	D
A-B	17			17			
A-C	806			806			
A-D	22			22			
AB-CD	22	623	0.035	22	0.0	5.985	A
AB-C	873			873			
D-AB	23	488	0.048	23	0.1	7.758	A
D-C	22	247	0.091	23	0.1	16.071	C
C-D	23			23			
C-A	469			469			
C-B	22			22			
CD-AB	23	472	0.048	23	0.1	8.018	A
CD-A	492			492			

08:45 - 09:00

Stream	Total Demand (PCU/hr)	Capacity (PCU/hr)	RFC	Throughput (PCU/hr)	End queue (PCU)	Delay (s)	LOS
B-ACD	127	341	0.373	129	0.6	17.144	C
A-B	14			14			
A-C	675			675			
A-D	18			18			
AB-CD	18	648	0.028	18	0.0	5.715	A
AB-C	729			729			
D-AB	20	510	0.038	20	0.0	7.336	A
D-C	19	286	0.066	19	0.1	13.501	B
C-D	20			20			
C-A	393			393			
C-B	18			18			
CD-AB	19	498	0.037	19	0.0	7.511	A
CD-A	412			412			

2017 + Allocation + Improvements, PM

Data Errors and Warnings

Severity	Area	Item	Description
Warning	Minor arm flare	Arm D - Minor arm geometry	Is flare very short? Estimated flare length is zero but has been increased to 1 because a zero flare length is not allowed.
Warning	Vehicle Mix		HV% is zero for all movements / time segments. Vehicle Mix matrix should be completed whether working in PCUs or Vehs.

Junction Network

Junctions

Junction	Name	Junction Type	Major road direction	Junction Delay (s)	Junction LOS
1	High Street Junctions	Left-Right Stagger	Two-way	0.62	A

Junction Network Options

Driving side	Lighting	Network residual capacity (%)	First arm reaching threshold
Left	Normal/unknown	67	Stream D-C

Traffic Demand

Demand Set Details

ID	Scenario name	Time Period name	Traffic profile type	Start time (HH:mm)	Finish time (HH:mm)	Time segment length (min)
D8	2017 + Allocation + Improvements	PM	ONE HOUR	16:45	18:15	15

Vehicle mix source	PCU Factor for a HV (PCU)
HV Percentages	2.00

Demand overview (Traffic)

Arm	Linked arm	Use O-D data	Average Demand (PCU/hr)	Scaling Factor (%)
A		✓	399	100.000
B		✓	59	100.000
C		✓	658	100.000
D		✓	24	100.000

Origin-Destination Data

Demand (PCU/hr)

		To			
		A	B	C	D
From	A	0	38	350	11
	B	22	0	37	0
	C	574	56	0	28
	D	10	0	14	0

Vehicle Mix

Heavy Vehicle Percentages

	To				
	A	B	C	D	
From	A	0	0	0	0
	B	0	0	0	0
	C	0	0	0	0
	D	0	0	0	0

Results

Results Summary for whole modelled period

Stream	Max RFC	Max delay (s)	Max Queue (PCU)	Max LOS
B-ACD	0.15	10.11	0.2	B
A-B				
A-C				
A-D				
AB-CD	0.02	6.56	0.0	A
AB-C				
D-AB	0.03	8.72	0.0	A
D-C	0.06	13.63	0.1	B
C-D				
C-A				
C-B				
CD-AB	0.11	6.52	0.1	A
CD-A				

Main Results for each time segment

16:45 - 17:00

Stream	Total Demand (PCU/hr)	Capacity (PCU/hr)	RFC	Throughput (PCU/hr)	End queue (PCU)	Delay (s)	LOS
B-ACD	44	479	0.093	44	0.1	8.267	A
A-B	29			29			
A-C	263			263			
A-D	8			8			
AB-CD	8	629	0.013	8	0.0	5.801	A
AB-C	291			291			
D-AB	8	477	0.016	7	0.0	7.673	A
D-C	11	351	0.030	10	0.0	10.560	B
C-D	21			21			
C-A	432			432			
C-B	42			42			
CD-AB	44	617	0.072	44	0.1	6.283	A
CD-A	437			437			

17:00 - 17:15

Stream	Total Demand (PCU/hr)	Capacity (PCU/hr)	RFC	Throughput (PCU/hr)	End queue (PCU)	Delay (s)	LOS
B-ACD	53	455	0.117	53	0.1	8.945	A
A-B	34			34			
A-C	315			315			
A-D	10			10			
AB-CD	10	600	0.016	10	0.0	6.095	A
AB-C	348			348			
D-AB	9	455	0.020	9	0.0	8.080	A
D-C	13	321	0.039	13	0.0	11.665	B
C-D	25			25			
C-A	516			516			
C-B	50			50			
CD-AB	54	617	0.088	54	0.1	6.399	A
CD-A	521			521			

17:15 - 17:30

Stream	Total Demand (PCU/hr)	Capacity (PCU/hr)	RFC	Throughput (PCU/hr)	End queue (PCU)	Delay (s)	LOS
B-ACD	65	421	0.154	65	0.2	10.098	B
A-B	42			42			
A-C	385			385			
A-D	12			12			
AB-CD	12	561	0.022	12	0.0	6.555	A
AB-C	426			426			
D-AB	11	424	0.026	11	0.0	8.717	A
D-C	15	279	0.055	15	0.1	13.631	B
C-D	31			31			
C-A	632			632			
C-B	62			62			
CD-AB	70	622	0.112	70	0.1	6.514	A
CD-A	635			635			

17:30 - 17:45

Stream	Total Demand (PCU/hr)	Capacity (PCU/hr)	RFC	Throughput (PCU/hr)	End queue (PCU)	Delay (s)	LOS
B-ACD	65	421	0.154	65	0.2	10.109	B
A-B	42			42			
A-C	385			385			
A-D	12			12			
AB-CD	12	561	0.022	12	0.0	6.555	A
AB-C	426			426			
D-AB	11	424	0.026	11	0.0	8.720	A
D-C	15	279	0.055	15	0.1	13.633	B
C-D	31			31			
C-A	632			632			
C-B	62			62			
CD-AB	70	622	0.112	70	0.1	6.518	A
CD-A	635			635			

17:45 - 18:00

Stream	Total Demand (PCU/hr)	Capacity (PCU/hr)	RFC	Throughput (PCU/hr)	End queue (PCU)	Delay (s)	LOS
B-ACD	53	455	0.117	53	0.1	8.961	A
A-B	34			34			
A-C	315			315			
A-D	10			10			
AB-CD	10	600	0.016	10	0.0	6.096	A
AB-C	348			348			
D-AB	9	454	0.020	9	0.0	8.085	A
D-C	13	321	0.039	13	0.0	11.668	B
C-D	25			25			
C-A	516			516			
C-B	50			50			
CD-AB	54	617	0.088	55	0.1	6.403	A
CD-A	521			521			

18:00 - 18:15

Stream	Total Demand (PCU/hr)	Capacity (PCU/hr)	RFC	Throughput (PCU/hr)	End queue (PCU)	Delay (s)	LOS
B-ACD	44	479	0.093	45	0.1	8.290	A
A-B	29			29			
A-C	263			263			
A-D	8			8			
AB-CD	8	629	0.013	8	0.0	5.803	A
AB-C	291			291			
D-AB	8	476	0.016	8	0.0	7.680	A
D-C	11	351	0.030	11	0.0	10.566	B
C-D	21			21			
C-A	432			432			
C-B	42			42			
CD-AB	44	617	0.072	45	0.1	6.290	A
CD-A	437			437			

10% reduction, AM

Data Errors and Warnings

Severity	Area	Item	Description
Warning	Minor arm flare	Arm D - Minor arm geometry	Is flare very short? Estimated flare length is zero but has been increased to 1 because a zero flare length is not allowed.
Warning	Vehicle Mix		HV% is zero for all movements / time segments. Vehicle Mix matrix should be completed whether working in PCUs or Vehs.

Junction Network

Junctions

Junction	Name	Junction Type	Major road direction	Junction Delay (s)	Junction LOS
1	High Street Junctions	Left-Right Stagger	Two-way	16.76	C

Junction Network Options

Driving side	Lighting	Network residual capacity (%)	First arm reaching threshold
Left	Normal/unknown	-21	Stream B-ACD

Traffic Demand

Demand Set Details

ID	Scenario name	Time Period name	Traffic profile type	Start time (HH:mm)	Finish time (HH:mm)	Time segment length (min)
D9	10% reduction	AM	ONE HOUR	07:30	09:00	15

Vehicle mix source	PCU Factor for a HV (PCU)
HV Percentages	2.00

Demand overview (Traffic)

Arm	Linked arm	Use O-D data	Average Demand (PCU/hr)	Scaling Factor (%)
A		✓	1196	100.000
B		✓	169	100.000
C		✓	572	100.000
D		✓	51	100.000

Origin-Destination Data

Demand (PCU/hr)

		To			
		A	B	C	D
From	A	0	19	1153	24
	B	99	0	70	0
	C	522	24	0	26
	D	26	0	25	0

Vehicle Mix

Heavy Vehicle Percentages

	To				
	A	B	C	D	
From	A	0	0	0	0
	B	0	0	0	0
	C	0	0	0	0
	D	0	0	0	0

Results

Results Summary for whole modelled period

Stream	Max RFC	Max delay (s)	Max Queue (PCU)	Max LOS
B-ACD	1.20	369.42	20.0	F
A-B				
A-C				
A-D				
AB-CD	0.04	6.40	0.0	A
AB-C				
D-AB	0.06	8.57	0.1	A
D-C	0.18	28.62	0.2	D
C-D				
C-A				
C-B				
CD-AB	0.08	10.36	0.1	B
CD-A				

Main Results for each time segment

07:30 - 07:45

Stream	Total Demand (PCU/hr)	Capacity (PCU/hr)	RFC	Throughput (PCU/hr)	End queue (PCU)	Delay (s)	LOS
B-ACD	127	293	0.434	124	0.7	20.995	C
A-B	14			14			
A-C	868			868			
A-D	18			18			
AB-CD	18	648	0.028	18	0.0	5.715	A
AB-C	920			920			
D-AB	20	510	0.038	19	0.0	7.332	A
D-C	19	259	0.073	19	0.1	14.948	B
C-D	20			20			
C-A	393			393			
C-B	18			18			
CD-AB	19	451	0.042	19	0.0	8.312	A
CD-A	412			412			

07:45 - 08:00

Stream	Total Demand (PCU/hr)	Capacity (PCU/hr)	RFC	Throughput (PCU/hr)	End queue (PCU)	Delay (s)	LOS
B-ACD	152	237	0.641	148	1.6	39.171	E
A-B	17			17			
A-C	1037			1037			
A-D	22			22			
AB-CD	22	623	0.035	22	0.0	5.982	A
AB-C	1098			1098			
D-AB	23	487	0.048	23	0.1	7.771	A
D-C	22	216	0.104	22	0.1	18.624	C
C-D	23			23			
C-A	469			469			
C-B	22			22			
CD-AB	23	417	0.055	23	0.1	9.126	A
CD-A	491			491			

08:00 - 08:15

Stream	Total Demand (PCU/hr)	Capacity (PCU/hr)	RFC	Throughput (PCU/hr)	End queue (PCU)	Delay (s)	LOS
B-ACD	186	155	1.201	146	11.6	202.541	F
A-B	21			21			
A-C	1269			1269			
A-D	26			26			
AB-CD	26	589	0.045	26	0.0	6.396	A
AB-C	1330			1330			
D-AB	29	450	0.064	29	0.1	8.540	A
D-C	28	155	0.177	27	0.2	28.000	D
C-D	29			29			
C-A	575			575			
C-B	26			26			
CD-AB	30	378	0.080	30	0.1	10.355	B
CD-A	599			599			

08:15 - 08:30

Stream	Total Demand (PCU/hr)	Capacity (PCU/hr)	RFC	Throughput (PCU/hr)	End queue (PCU)	Delay (s)	LOS
B-ACD	186	155	1.202	153	20.0	369.421	F
A-B	21			21			
A-C	1269			1269			
A-D	26			26			
AB-CD	26	589	0.045	26	0.0	6.396	A
AB-C	1333			1333			
D-AB	29	449	0.064	29	0.1	8.570	A
D-C	28	153	0.180	28	0.2	28.618	D
C-D	29			29			
C-A	575			575			
C-B	26			26			
CD-AB	30	378	0.080	30	0.1	10.364	B
CD-A	599			599			

08:30 - 08:45

Stream	Total Demand (PCU/hr)	Capacity (PCU/hr)	RFC	Throughput (PCU/hr)	End queue (PCU)	Delay (s)	LOS
B-ACD	152	237	0.641	221	2.6	192.440	F
A-B	17			17			
A-C	1037			1037			
A-D	22			22			
AB-CD	22	623	0.035	22	0.0	5.983	A
AB-C	1128			1128			
D-AB	23	485	0.048	23	0.1	7.804	A
D-C	22	212	0.106	23	0.1	19.095	C
C-D	23			23			
C-A	469			469			
C-B	22			22			
CD-AB	23	417	0.055	23	0.1	9.135	A
CD-A	491			491			

08:45 - 09:00

Stream	Total Demand (PCU/hr)	Capacity (PCU/hr)	RFC	Throughput (PCU/hr)	End queue (PCU)	Delay (s)	LOS
B-ACD	127	293	0.434	134	0.8	23.635	C
A-B	14			14			
A-C	868			868			
A-D	18			18			
AB-CD	18	648	0.028	18	0.0	5.715	A
AB-C	924			924			
D-AB	20	509	0.038	20	0.0	7.358	A
D-C	19	259	0.073	19	0.1	15.011	C
C-D	20			20			
C-A	393			393			
C-B	18			18			
CD-AB	19	451	0.042	19	0.0	8.324	A
CD-A	412			412			



Technical Note

APPENDIX C - TRICS OUTPUT FILES

Calculation Reference: AUDIT-141301-171026-1015

TRIP RATE CALCULATION SELECTION PARAMETERS:

Land Use : 02 - EMPLOYMENT

Category : A - OFFICE

VEHICLES

Selected regions and areas:

02	SOUTH EAST	
	HC HAMPSHIRE	2 days
	KC KENT	1 days
	SC SURREY	3 days
03	SOUTH WEST	
	DC DORSET	1 days
04	EAST ANGLIA	
	SF SUFFOLK	1 days

This section displays the number of survey days per TRICS® sub-region in the selected set

Secondary Filtering selection:

This data displays the chosen trip rate parameter and its selected range. Only sites that fall within the parameter range are included in the trip rate calculation.

Parameter: Gross floor area
 Actual Range: 8000 to 33180 (units: sqm)
 Range Selected by User: 7500 to 50000 (units: sqm)

Public Transport Provision:

Selection by: Include all surveys

Date Range: 01/01/09 to 23/11/15

This data displays the range of survey dates selected. Only surveys that were conducted within this date range are included in the trip rate calculation.

Selected survey days:

Monday	5 days
Tuesday	3 days

This data displays the number of selected surveys by day of the week.

Selected survey types:

Manual count	8 days
Directional ATC Count	0 days

This data displays the number of manual classified surveys and the number of unclassified ATC surveys, the total adding up to the overall number of surveys in the selected set. Manual surveys are undertaken using staff, whilst ATC surveys are undertaken using machines.

Selected Locations:

Edge of Town Centre	2
Suburban Area (PPS6 Out of Centre)	3
Edge of Town	3

This data displays the number of surveys per main location category within the selected set. The main location categories consist of Free Standing, Edge of Town, Suburban Area, Neighbourhood Centre, Edge of Town Centre, Town Centre and Not Known.

Selected Location Sub Categories:

Industrial Zone	1
Commercial Zone	3
Residential Zone	1
Built-Up Zone	2
No Sub Category	1

This data displays the number of surveys per location sub-category within the selected set. The location sub-categories consist of Commercial Zone, Industrial Zone, Development Zone, Residential Zone, Retail Zone, Built-Up Zone, Village, Out of Town, High Street and No Sub Category.

Secondary Filtering selection:

Use Class:

B1	8 days
----	--------

This data displays the number of surveys per Use Class classification within the selected set. The Use Classes Order 2005 has been used for this purpose, which can be found within the Library module of TRICS®.

Population within 1 mile:

Not Known	1 days
5,001 to 10,000	2 days
10,001 to 15,000	1 days
15,001 to 20,000	2 days
25,001 to 50,000	2 days

This data displays the number of selected surveys within stated 1-mile radii of population.

Population within 5 miles:

Not Known	1 days
25,001 to 50,000	2 days
75,001 to 100,000	1 days
125,001 to 250,000	1 days
250,001 to 500,000	3 days

This data displays the number of selected surveys within stated 5-mile radii of population.

Car ownership within 5 miles:

0.6 to 1.0	1 days
1.1 to 1.5	5 days
1.6 to 2.0	2 days

This data displays the number of selected surveys within stated ranges of average cars owned per residential dwelling, within a radius of 5-miles of selected survey sites.

Travel Plan:

Yes	7 days
No	1 days

This data displays the number of surveys within the selected set that were undertaken at sites with Travel Plans in place, and the number of surveys that were undertaken at sites without Travel Plans.

PTAL Rating:

No PTAL Present	8 days
-----------------	--------

This data displays the number of selected surveys with PTAL Ratings.

LIST OF SITES relevant to selection parameters

1	DC-02-A-09	COUNCIL OFFICES		DORSET
		THE GROVE		
		DORCHESTER		
		Edge of Town Centre		
		Built-Up Zone		
		Total Gross floor area:	11664 sqm	
		Survey date: MONDAY	28/11/11	Survey Type: MANUAL
2	HC-02-A-11	DIY CO. HQ		HAMPSHIRE
		CHESTNUT AVENUE		
		CHANDLER'S FORD		
		Edge of Town		
		Commercial Zone		
		Total Gross floor area:	26100 sqm	
		Survey date: MONDAY	17/10/11	Survey Type: MANUAL
3	HC-02-A-12	HMRC		HAMPSHIRE
		NORTHERN ROAD		
		COSHAM		
		PORTSMOUTH		
		Suburban Area (PPS6 Out of Centre)		
		No Sub Category		
		Total Gross floor area:	10100 sqm	
		Survey date: MONDAY	23/11/15	Survey Type: MANUAL
4	KC-02-A-11	COUNTY HALL		KENT
		SANDLING ROAD		
		MAIDSTONE		
		Edge of Town Centre		
		Built-Up Zone		
		Total Gross floor area:	32793 sqm	
		Survey date: MONDAY	17/10/11	Survey Type: MANUAL
5	SC-02-A-14	UNILEVER		SURREY
		SPRINGFIELD DRIVE		
		LEATHERHEAD		
		Edge of Town		
		Commercial Zone		
		Total Gross floor area:	19974 sqm	
		Survey date: TUESDAY	10/03/09	Survey Type: MANUAL
6	SC-02-A-16	BANK OF AMERICA		SURREY
		STANHOPE ROAD		
		CAMBERLEY		
		Edge of Town		
		Commercial Zone		
		Total Gross floor area:	39230 sqm	
		Survey date: TUESDAY	10/05/11	Survey Type: MANUAL

LIST OF SITES relevant to selection parameters (Cont.)

7	SC-02-A-17 PHARMACEUTICALS ST GEORGE'S AVENUE THE HEATH WEYBRIDGE Suburban Area (PPS6 Out of Centre) Residential Zone Total Gross floor area: 10293 sqm Survey date: TUESDAY 18/10/11	SURREY Survey Type: MANUAL
8	SF-02-A-01 COUNCIL OFFICES BEETONS WAY BURY ST. EDMUNDS Suburban Area (PPS6 Out of Centre) Industrial Zone Total Gross floor area: 8000 sqm Survey date: MONDAY 27/09/10	SUFFOLK Survey Type: MANUAL

This section provides a list of all survey sites and days in the selected set. For each individual survey site, it displays a unique site reference code and site address, the selected trip rate calculation parameter and its value, the day of the week and date of each survey, and whether the survey was a manual classified count or an ATC count.

TRIP RATE for Land Use 02 - EMPLOYMENT/A - OFFICE
VEHICLES

Calculation factor: 100 sqm

BOLD print indicates peak (busiest) period

Time Range	ARRIVALS			DEPARTURES			TOTALS		
	No. Days	Ave. GFA	Trip Rate	No. Days	Ave. GFA	Trip Rate	No. Days	Ave. GFA	Trip Rate
00:00 - 00:30									
00:30 - 01:00									
01:00 - 01:30									
01:30 - 02:00									
02:00 - 02:30									
02:30 - 03:00									
03:00 - 03:30									
03:30 - 04:00									
04:00 - 04:30									
04:30 - 05:00									
05:00 - 05:30	1	19974	0.000	1	19974	0.005	1	19974	0.005
05:30 - 06:00	1	19974	0.020	1	19974	0.005	1	19974	0.025
06:00 - 06:30	2	15037	0.183	2	15037	0.013	2	15037	0.196
06:30 - 07:00	2	15037	0.306	2	15037	0.063	2	15037	0.369
07:00 - 07:30	8	18794	0.182	8	18794	0.011	8	18794	0.193
07:30 - 08:00	8	18794	0.418	8	18794	0.037	8	18794	0.455
08:00 - 08:30	8	18794	0.643	8	18794	0.049	8	18794	0.692
08:30 - 09:00	8	18794	0.777	8	18794	0.084	8	18794	0.861
09:00 - 09:30	8	18794	0.557	8	18794	0.104	8	18794	0.661
09:30 - 10:00	8	18794	0.300	8	18794	0.102	8	18794	0.402
10:00 - 10:30	8	18794	0.191	8	18794	0.084	8	18794	0.275
10:30 - 11:00	8	18794	0.148	8	18794	0.082	8	18794	0.230
11:00 - 11:30	8	18794	0.144	8	18794	0.117	8	18794	0.261
11:30 - 12:00	8	18794	0.120	8	18794	0.105	8	18794	0.225
12:00 - 12:30	8	18794	0.105	8	18794	0.115	8	18794	0.220
12:30 - 13:00	8	18794	0.108	8	18794	0.124	8	18794	0.232
13:00 - 13:30	8	18794	0.137	8	18794	0.121	8	18794	0.258
13:30 - 14:00	8	18794	0.124	8	18794	0.090	8	18794	0.214
14:00 - 14:30	8	18794	0.108	8	18794	0.107	8	18794	0.215
14:30 - 15:00	8	18794	0.108	8	18794	0.160	8	18794	0.268
15:00 - 15:30	8	18794	0.079	8	18794	0.194	8	18794	0.273
15:30 - 16:00	8	18794	0.090	8	18794	0.227	8	18794	0.317
16:00 - 16:30	8	18794	0.075	8	18794	0.396	8	18794	0.471
16:30 - 17:00	8	18794	0.083	8	18794	0.476	8	18794	0.559
17:00 - 17:30	8	18794	0.059	8	18794	0.792	8	18794	0.851
17:30 - 18:00	8	18794	0.049	8	18794	0.470	8	18794	0.519
18:00 - 18:30	8	18794	0.029	8	18794	0.340	8	18794	0.369
18:30 - 19:00	8	18794	0.015	8	18794	0.170	8	18794	0.185
19:00 - 19:30									
19:30 - 20:00									
20:00 - 20:30									
20:30 - 21:00									
21:00 - 21:30									
21:30 - 22:00									
22:00 - 22:30									
22:30 - 23:00									
23:00 - 23:30									
23:30 - 24:00									
Total Rates:			5.158			4.643			9.801

This section displays the trip rate results based on the selected set of surveys and the selected count type (shown just above the table). It is split by three main columns, representing arrivals trips, departures trips, and total trips (arrivals plus departures). Within each of these main columns are three sub-columns. These display the number of survey days where count data is included (per time period), the average value of the selected trip rate calculation parameter (per time period), and the trip rate result (per time period). Total trip rates (the sum of the column) are also displayed at the foot of the table.

To obtain a trip rate, the average (mean) trip rate parameter value (TRP) is first calculated for all selected survey days that have count data available for the stated time period. The average (mean) number of arrivals, departures or totals (whichever applies) is also calculated (COUNT) for all selected survey days that have count data available for the stated time period. Then, the average count is divided by the average trip rate parameter value, and multiplied by the stated calculation factor (shown just above the table and abbreviated here as FACT). So, the method is: $COUNT/TRP*FACT$. Trip rates are then rounded to 3 decimal places.

Parameter summary

Trip rate parameter range selected:	8000 - 33180 (units: sqm)
Survey date date range:	01/01/09 - 23/11/15
Number of weekdays (Monday-Friday):	8
Number of Saturdays:	0
Number of Sundays:	0
Surveys automatically removed from selection:	0
Surveys manually removed from selection:	0

This section displays a quick summary of some of the data filtering selections made by the TRICS® user. The trip rate calculation parameter range of all selected surveys is displayed first, followed by the range of minimum and maximum survey dates selected by the user. Then, the total number of selected weekdays and weekend days in the selected set of surveys are shown. Finally, the number of survey days that have been manually removed from the selected set outside of the standard filtering procedure are displayed.

Calculation Reference: AUDIT-141301-171026-1042

TRIP RATE CALCULATION SELECTION PARAMETERS:

Land Use : 02 - EMPLOYMENT
 Category : F - WAREHOUSING (COMMERCIAL)
 VEHICLES

Selected regions and areas:

04	EAST ANGLIA	
	SF SUFFOLK	1 days
05	EAST MIDLANDS	
	DS DERBYSHIRE	1 days
06	WEST MIDLANDS	
	WM WEST MIDLANDS	2 days
07	YORKSHIRE & NORTH LINCOLNSHIRE	
	WY WEST YORKSHIRE	1 days
09	NORTH	
	CB CUMBRIA	1 days
	TV TEES VALLEY	1 days

This section displays the number of survey days per TRICS® sub-region in the selected set

Secondary Filtering selection:

This data displays the chosen trip rate parameter and its selected range. Only sites that fall within the parameter range are included in the trip rate calculation.

Parameter: Gross floor area
 Actual Range: 634 to 4700 (units: sqm)
 Range Selected by User: 634 to 20000 (units: sqm)

Public Transport Provision:

Selection by: Include all surveys

Date Range: 01/01/09 to 19/09/16

This data displays the range of survey dates selected. Only surveys that were conducted within this date range are included in the trip rate calculation.

Selected survey days:

Monday	2 days
Tuesday	3 days
Wednesday	1 days
Friday	1 days

This data displays the number of selected surveys by day of the week.

Selected survey types:

Manual count	7 days
Directional ATC Count	0 days

This data displays the number of manual classified surveys and the number of unclassified ATC surveys, the total adding up to the overall number of surveys in the selected set. Manual surveys are undertaken using staff, whilst ATC surveys are undertaken using machines.

Selected Locations:

Edge of Town Centre	3
Suburban Area (PPS6 Out of Centre)	1
Edge of Town	3

This data displays the number of surveys per main location category within the selected set. The main location categories consist of Free Standing, Edge of Town, Suburban Area, Neighbourhood Centre, Edge of Town Centre, Town Centre and Not Known.

Selected Location Sub Categories:

Industrial Zone	4
Commercial Zone	2
Built-Up Zone	1

This data displays the number of surveys per location sub-category within the selected set. The location sub-categories consist of Commercial Zone, Industrial Zone, Development Zone, Residential Zone, Retail Zone, Built-Up Zone, Village

Secondary Filtering selection:

Use Class:

B8 6 days

This data displays the number of surveys per Use Class classification within the selected set. The Use Classes Order 2005 has been used for this purpose, which can be found within the Library module of TRICS®.

Population within 1 mile:

5,001 to 10,000 3 days

10,001 to 15,000 1 days

25,001 to 50,000 3 days

This data displays the number of selected surveys within stated 1-mile radii of population.

Population within 5 miles:

5,001 to 25,000 2 days

25,001 to 50,000 1 days

125,001 to 250,000 1 days

250,001 to 500,000 1 days

500,001 or More 2 days

This data displays the number of selected surveys within stated 5-mile radii of population.

Car ownership within 5 miles:

0.6 to 1.0 5 days

1.1 to 1.5 2 days

This data displays the number of selected surveys within stated ranges of average cars owned per residential dwelling, within a radius of 5-miles of selected survey sites.

Travel Plan:

No 7 days

This data displays the number of surveys within the selected set that were undertaken at sites with Travel Plans in place, and the number of surveys that were undertaken at sites without Travel Plans.

PTAL Rating:

No PTAL Present 7 days

This data displays the number of selected surveys with PTAL Ratings.

LIST OF SITES relevant to selection parameters

1	CB-02-F-01 COWPER ROAD GILWILLY IND. ESTATE PENRITH Edge of Town Industrial Zone Total Gross floor area: 2950 sqm Survey date: TUESDAY 10/06/14	DOMINO'S PIZZA	CUMBRIA	Survey Type: MANUAL
2	DS-02-F-01 FORRESTERS BUSINESS P.. SINFIN LANE DERBY Edge of Town Centre Commercial Zone Total Gross floor area: 1900 sqm Survey date: TUESDAY 05/07/11	ARMADILLO S. STORAGE	DERBYSHIRE	Survey Type: MANUAL
3	SF-02-F-03 CENTRAL AVENUE WARREN HEATH IPSWICH Edge of Town Industrial Zone Total Gross floor area: 4700 sqm Survey date: FRIDAY 18/09/15	ROAD HAULAGE	SUFFOLK	Survey Type: MANUAL
4	TV-02-F-03 UNIT 8,NAVIGATOR COURT STOCKTON-ON-TEES Suburban Area (PPS6 Out of Centre) Industrial Zone Total Gross floor area: 634 sqm Survey date: TUESDAY 28/06/11	ELECTRICAL COMPONENTS	TEES VALLEY	Survey Type: MANUAL
5	WM-02-F-01 SAMPSON ROAD NORTH BIRMINGHAM Edge of Town Centre Industrial Zone Total Gross floor area: 4000 sqm Survey date: WEDNESDAY 17/06/09	LEGETT LOGIS.	WEST MIDLANDS	Survey Type: MANUAL
6	WM-02-F-02 SOVEREIGN ROAD KINGS NORTON BIRMINGHAM Edge of Town Commercial Zone Total Gross floor area: 3625 sqm Survey date: MONDAY 09/11/15	LOGISTICS FIRM	WEST MIDLANDS	Survey Type: MANUAL
7	WY-02-F-01 MORTIMER STREET CLECKHEATON Edge of Town Centre Built-Up Zone Total Gross floor area: 1507 sqm Survey date: MONDAY 19/09/16	ELECTRONICS DISTRIBUTION	WEST YORKSHIRE	Survey Type: MANUAL

This section provides a list of all survey sites and days in the selected set. For each individual survey site, it displays a unique site reference code and site address, the selected trip rate calculation parameter and its value, the day of the week and date of each survey, and whether the survey was a manual classified count or an ATC count.

TRIP RATE for Land Use 02 - EMPLOYMENT/F - WAREHOUSING (COMMERCIAL)
VEHICLES

Calculation factor: 100 sqm

BOLD print indicates peak (busiest) period

Time Range	ARRIVALS			DEPARTURES			TOTALS		
	No. Days	Ave. GFA	Trip Rate	No. Days	Ave. GFA	Trip Rate	No. Days	Ave. GFA	Trip Rate
00:00 - 00:30									
00:30 - 01:00									
01:00 - 01:30									
01:30 - 02:00									
02:00 - 02:30									
02:30 - 03:00									
03:00 - 03:30									
03:30 - 04:00									
04:00 - 04:30									
04:30 - 05:00									
05:00 - 05:30	1	1976	0.000	1	1976	0.000	1	1976	0.000
05:30 - 06:00	1	1976	0.152	1	1976	0.000	1	1976	0.152
06:00 - 06:30	1	1976	0.051	1	1976	0.000	1	1976	0.051
06:30 - 07:00	1	1976	0.152	1	1976	0.051	1	1976	0.203
07:00 - 07:30	7	2620	0.098	7	2620	0.049	7	2620	0.147
07:30 - 08:00	7	2620	0.153	7	2620	0.049	7	2620	0.202
08:00 - 08:30	7	2620	0.196	7	2620	0.065	7	2620	0.261
08:30 - 09:00	7	2620	0.256	7	2620	0.087	7	2620	0.343
09:00 - 09:30	7	2620	0.109	7	2620	0.065	7	2620	0.174
09:30 - 10:00	7	2620	0.082	7	2620	0.055	7	2620	0.137
10:00 - 10:30	7	2620	0.114	7	2620	0.093	7	2620	0.207
10:30 - 11:00	7	2620	0.087	7	2620	0.114	7	2620	0.201
11:00 - 11:30	7	2620	0.098	7	2620	0.104	7	2620	0.202
11:30 - 12:00	7	2620	0.109	7	2620	0.076	7	2620	0.185
12:00 - 12:30	7	2620	0.125	7	2620	0.114	7	2620	0.239
12:30 - 13:00	7	2620	0.109	7	2620	0.087	7	2620	0.196
13:00 - 13:30	7	2620	0.136	7	2620	0.142	7	2620	0.278
13:30 - 14:00	7	2620	0.131	7	2620	0.087	7	2620	0.218
14:00 - 14:30	7	2620	0.114	7	2620	0.125	7	2620	0.239
14:30 - 15:00	7	2620	0.109	7	2620	0.109	7	2620	0.218
15:00 - 15:30	7	2620	0.087	7	2620	0.120	7	2620	0.207
15:30 - 16:00	7	2620	0.060	7	2620	0.104	7	2620	0.164
16:00 - 16:30	7	2620	0.071	7	2620	0.104	7	2620	0.175
16:30 - 17:00	7	2620	0.071	7	2620	0.131	7	2620	0.202
17:00 - 17:30	7	2620	0.049	7	2620	0.262	7	2620	0.311
17:30 - 18:00	7	2620	0.027	7	2620	0.147	7	2620	0.174
18:00 - 18:30	6	2806	0.042	6	2806	0.137	6	2806	0.179
18:30 - 19:00	6	2806	0.030	6	2806	0.071	6	2806	0.101
19:00 - 19:30	1	1976	0.253	1	1976	0.152	1	1976	0.405
19:30 - 20:00	1	1976	0.051	1	1976	0.152	1	1976	0.203
20:00 - 20:30	1	1976	0.051	1	1976	0.051	1	1976	0.102
20:30 - 21:00	1	1976	0.101	1	1976	0.152	1	1976	0.253
21:00 - 21:30									
21:30 - 22:00									
22:00 - 22:30									
22:30 - 23:00									
23:00 - 23:30									
23:30 - 24:00									
Total Rates:			3.274			3.055			6.329

This section displays the trip rate results based on the selected set of surveys and the selected count type (shown just above the table). It is split by three main columns, representing arrivals trips, departures trips, and total trips (arrivals plus departures). Within each of these main columns are three sub-columns. These display the number of survey days where count data is included (per time period), the average value of the selected trip rate calculation parameter (per time period), and the trip rate result (per time period). Total trip rates (the sum of the column) are also displayed at the foot of the table.

To obtain a trip rate, the average (mean) trip rate parameter value (TRP) is first calculated for all selected survey days that have count data available for the stated time period. The average (mean) number of arrivals, departures or totals (whichever applies) is also calculated (COUNT) for all selected survey days that have count data available for the stated time period. Then, the average count is divided by the average trip rate parameter value, and multiplied by the stated calculation factor (shown just above the table and abbreviated here as FACT). So, the method is: $COUNT/TRP*FACT$. Trip rates are then rounded to 3 decimal places.

Parameter summary

Trip rate parameter range selected:	634 - 4700 (units: sqm)
Survey date date range:	01/01/09 - 19/09/16
Number of weekdays (Monday-Friday):	7
Number of Saturdays:	0
Number of Sundays:	0
Surveys automatically removed from selection:	0
Surveys manually removed from selection:	0

This section displays a quick summary of some of the data filtering selections made by the TRICS® user. The trip rate calculation parameter range of all selected surveys is displayed first, followed by the range of minimum and maximum survey dates selected by the user. Then, the total number of selected weekdays and weekend days in the selected set of surveys are show. Finally, the number of survey days that have been manually removed from the selected set outside of the standard filtering procedure are displayed.

Calculation Reference: AUDIT-141301-171026-1044

TRIP RATE CALCULATION SELECTION PARAMETERS:

Land Use : 03 - RESIDENTIAL
 Category : A - HOUSES PRIVATELY OWNED
 VEHICLES

Selected regions and areas:

02	SOUTH EAST	
	HC HAMPSHIRE	1 days
	SC SURREY	1 days
	WS WEST SUSSEX	2 days
03	SOUTH WEST	
	DV DEVON	2 days
04	EAST ANGLIA	
	NF NORFOLK	1 days
06	WEST MIDLANDS	
	SH SHROPSHIRE	2 days
07	YORKSHIRE & NORTH LINCOLNSHIRE	
	NE NORTH EAST LINCOLNSHIRE	1 days
	NY NORTH YORKSHIRE	3 days
	SY SOUTH YORKSHIRE	1 days

This section displays the number of survey days per TRICS® sub-region in the selected set

Secondary Filtering selection:

This data displays the chosen trip rate parameter and its selected range. Only sites that fall within the parameter range are included in the trip rate calculation.

Parameter: Number of dwellings
 Actual Range: 52 to 805 (units:)
 Range Selected by User: 50 to 4334 (units:)

Public Transport Provision:

Selection by: Include all surveys

Date Range: 01/01/09 to 28/03/17

This data displays the range of survey dates selected. Only surveys that were conducted within this date range are included in the trip rate calculation.

Selected survey days:

Monday	3 days
Tuesday	3 days
Wednesday	1 days
Thursday	5 days
Friday	2 days

This data displays the number of selected surveys by day of the week.

Selected survey types:

Manual count	14 days
Directional ATC Count	0 days

This data displays the number of manual classified surveys and the number of unclassified ATC surveys, the total adding up to the overall number of surveys in the selected set. Manual surveys are undertaken using staff, whilst ATC surveys are undertaken using machines.

Selected Locations:

Edge of Town Centre	1
Suburban Area (PPS6 Out of Centre)	8
Edge of Town	5

This data displays the number of surveys per main location category within the selected set. The main location categories consist of Free Standing, Edge of Town, Suburban Area, Neighbourhood Centre, Edge of Town Centre, Town Centre and Not Known.

Selected Location Sub Categories:

Residential Zone	12
No Sub Category	2

This data displays the number of surveys per location sub-category within the selected set. The location sub-categories consist of Commercial Zone, Industrial Zone, Development Zone, Residential Zone, Retail Zone, Built-Up Zone, Village, Out of Town, High Street and No Sub Category.

Secondary Filtering selection:

Use Class:

C3 14 days

This data displays the number of surveys per Use Class classification within the selected set. The Use Classes Order 2005 has been used for this purpose, which can be found within the Library module of TRICS®.

Population within 1 mile:

1,001 to 5,000	3 days
5,001 to 10,000	5 days
10,001 to 15,000	4 days
15,001 to 20,000	1 days
20,001 to 25,000	1 days

This data displays the number of selected surveys within stated 1-mile radii of population.

Population within 5 miles:

5,001 to 25,000	4 days
25,001 to 50,000	2 days
75,001 to 100,000	5 days
100,001 to 125,000	1 days
125,001 to 250,000	1 days
250,001 to 500,000	1 days

This data displays the number of selected surveys within stated 5-mile radii of population.

Car ownership within 5 miles:

1.1 to 1.5 14 days

This data displays the number of selected surveys within stated ranges of average cars owned per residential dwelling, within a radius of 5-miles of selected survey sites.

Travel Plan:

Yes	3 days
No	11 days

This data displays the number of surveys within the selected set that were undertaken at sites with Travel Plans in place, and the number of surveys that were undertaken at sites without Travel Plans.

PTAL Rating:

No PTAL Present 14 days

This data displays the number of selected surveys with PTAL Ratings.

LIST OF SITES relevant to selection parameters

1	DV-03-A-02 MILLHEAD ROAD	HOUSES & BUNGALOWS	DEVON
	HONITON Suburban Area (PPS6 Out of Centre) Residential Zone Total Number of dwellings: 116 Survey date: FRIDAY 25/09/15		
2	DV-03-A-03 LOWER BRAND LANE	TERRACED & SEMI DETACHED	DEVON
	HONITON Suburban Area (PPS6 Out of Centre) Residential Zone Total Number of dwellings: 70 Survey date: MONDAY 28/09/15		
3	HC-03-A-18 CANADA WAY	HOUSES & FLATS	HAMPSHIRE
	LIPHOOK Suburban Area (PPS6 Out of Centre) Residential Zone Total Number of dwellings: 62 Survey date: TUESDAY 29/11/16		
4	NE-03-A-03 STATION ROAD	PRIVATE HOUSES	NORTH EAST LINCOLNSHIRE
	SCUNTHORPE Edge of Town Centre Residential Zone Total Number of dwellings: 180 Survey date: TUESDAY 20/05/14		
5	NF-03-A-02 DEREHAM ROAD	HOUSES & FLATS	NORFOLK
	NORWICH Suburban Area (PPS6 Out of Centre) Residential Zone Total Number of dwellings: 98 Survey date: MONDAY 22/10/12		
6	NY-03-A-06 HORSEFAIR	BUNGALOWS & SEMI DET.	NORTH YORKSHIRE
	BOROUGHBRIDGE Suburban Area (PPS6 Out of Centre) Residential Zone Total Number of dwellings: 115 Survey date: FRIDAY 14/10/11		
7	NY-03-A-09 GRAMMAR SCHOOL LANE	MIXED HOUSING	NORTH YORKSHIRE
	NORTHALLERTON Suburban Area (PPS6 Out of Centre) Residential Zone Total Number of dwellings: 52 Survey date: MONDAY 16/09/13		

LIST OF SITES relevant to selection parameters (Cont.)

8	NY-03-A-10	HOUSES AND FLATS		NORTH YORKSHIRE
		BOROUGHBRIDGE ROAD		
		RIPON		
		Edge of Town		
		No Sub Category		
		Total Number of dwellings:	71	
		Survey date: TUESDAY	17/09/13	Survey Type: MANUAL
9	SC-03-A-04	DETACHED & TERRACED		SURREY
		HIGH ROAD		
		BYFLEET		
		Edge of Town		
		Residential Zone		
		Total Number of dwellings:	71	
		Survey date: THURSDAY	23/01/14	Survey Type: MANUAL
10	SH-03-A-04	TERRACED		SHROPSHIRE
		ST MICHAEL'S STREET		
		SHREWSBURY		
		Suburban Area (PPS6 Out of Centre)		
		No Sub Category		
		Total Number of dwellings:	108	
		Survey date: THURSDAY	11/06/09	Survey Type: MANUAL
11	SH-03-A-05	SEMI -DETACHED/TERRACED		SHROPSHIRE
		SANDCROFT		
		SUTTON HILL		
		TELFORD		
		Edge of Town		
		Residential Zone		
		Total Number of dwellings:	54	
		Survey date: THURSDAY	24/10/13	Survey Type: MANUAL
12	SY-03-A-01	SEMI DETACHED HOUSES		SOUTH YORKSHIRE
		A19 BENTLEY ROAD		
		BENTLEY RISE		
		DONCASTER		
		Suburban Area (PPS6 Out of Centre)		
		Residential Zone		
		Total Number of dwellings:	54	
		Survey date: WEDNESDAY	18/09/13	Survey Type: MANUAL
13	WS-03-A-04	MIXED HOUSES		WEST SUSSEX
		HILLS FARM LANE		
		BROADBRIDGE HEATH		
		HORSHAM		
		Edge of Town		
		Residential Zone		
		Total Number of dwellings:	151	
		Survey date: THURSDAY	11/12/14	Survey Type: MANUAL

LIST OF SITES relevant to selection parameters (Cont.)

14	WS-03-A-06	MIXED HOUSES	WEST SUSSEX
	ELLIS ROAD		
	S BROADBRIDGE HEATH		
	WEST HORSHAM		
	Edge of Town		
	Residential Zone		
	Total Number of dwellings:	805	
	Survey date: THURSDAY	02/03/17	Survey Type: MANUAL

This section provides a list of all survey sites and days in the selected set. For each individual survey site, it displays a unique site reference code and site address, the selected trip rate calculation parameter and its value, the day of the week and date of each survey, and whether the survey was a manual classified count or an ATC count.

TRIP RATE for Land Use 03 - RESIDENTIAL/A - HOUSES PRIVATELY OWNED
VEHICLES

Calculation factor: 1 DWELLS

BOLD print indicates peak (busiest) period

Time Range	ARRIVALS			DEPARTURES			TOTALS		
	No. Days	Ave. DWELLS	Trip Rate	No. Days	Ave. DWELLS	Trip Rate	No. Days	Ave. DWELLS	Trip Rate
00:00 - 01:00									
01:00 - 02:00									
02:00 - 03:00									
03:00 - 04:00									
04:00 - 05:00									
05:00 - 06:00									
06:00 - 07:00									
07:00 - 08:00	14	143	0.077	14	143	0.306	14	143	0.383
08:00 - 09:00	14	143	0.148	14	143	0.392	14	143	0.540
09:00 - 10:00	14	143	0.155	14	143	0.163	14	143	0.318
10:00 - 11:00	14	143	0.125	14	143	0.156	14	143	0.281
11:00 - 12:00	14	143	0.144	14	143	0.152	14	143	0.296
12:00 - 13:00	14	143	0.147	14	143	0.146	14	143	0.293
13:00 - 14:00	14	143	0.156	14	143	0.149	14	143	0.305
14:00 - 15:00	14	143	0.138	14	143	0.171	14	143	0.309
15:00 - 16:00	14	143	0.235	14	143	0.160	14	143	0.395
16:00 - 17:00	14	143	0.242	14	143	0.157	14	143	0.399
17:00 - 18:00	14	143	0.327	14	143	0.163	14	143	0.490
18:00 - 19:00	14	143	0.268	14	143	0.159	14	143	0.427
19:00 - 20:00									
20:00 - 21:00									
21:00 - 22:00									
22:00 - 23:00									
23:00 - 24:00									
Total Rates:			2.162			2.274			4.436

This section displays the trip rate results based on the selected set of surveys and the selected count type (shown just above the table). It is split by three main columns, representing arrivals trips, departures trips, and total trips (arrivals plus departures). Within each of these main columns are three sub-columns. These display the number of survey days where count data is included (per time period), the average value of the selected trip rate calculation parameter (per time period), and the trip rate result (per time period). Total trip rates (the sum of the column) are also displayed at the foot of the table.

To obtain a trip rate, the average (mean) trip rate parameter value (TRP) is first calculated for all selected survey days that have count data available for the stated time period. The average (mean) number of arrivals, departures or totals (whichever applies) is also calculated (COUNT) for all selected survey days that have count data available for the stated time period. Then, the average count is divided by the average trip rate parameter value, and multiplied by the stated calculation factor (shown just above the table and abbreviated here as FACT). So, the method is: $COUNT/TRP*FACT$. Trip rates are then rounded to 3 decimal places.

Parameter summary

Trip rate parameter range selected: 52 - 805 (units:)
 Survey date date range: 01/01/09 - 28/03/17
 Number of weekdays (Monday-Friday): 14
 Number of Saturdays: 0
 Number of Sundays: 0
 Surveys automatically removed from selection: 0
 Surveys manually removed from selection: 0

This section displays a quick summary of some of the data filtering selections made by the TRICS® user. The trip rate calculation parameter range of all selected surveys is displayed first, followed by the range of minimum and maximum survey dates selected by the user. Then, the total number of selected weekdays and weekend days in the selected set of surveys are shown. Finally, the number of survey days that have been manually removed from the selected set outside of the standard filtering procedure are displayed.



Technical Note

APPENDIX D - 2011 CENSUS DATA - JTW

WU03EW - Location of usual residence and place of work by method of travel to work (MSOA level)

ONS Crown Copyright Reserved [from Nomis on 27 October 2017]

population All usual residents aged 16 and over in employment the week before the census
 units Persons
 date 2011
 method of travel to work Driving a car or van

place of work

usual residence : 2011 super output area - middle layer

E02004945 : Stevenage 002

			EC 1/7		EC 1/4
E02004945 : Stevenage 002	268	7	From South	12	From South
E02004949 : Stevenage 006	200	6	From South		From South
E02004944 : Stevenage 001	176	5	From South		From South
E02004913 : North Hertfordshire 005	167	5	S via Graveley		S via Graveley
E02004946 : Stevenage 003	167	5	From South		From South
E02004947 : Stevenage 004	153	4	From South		From South
E02004950 : Stevenage 007	145	4	From South		From South
E02004948 : Stevenage 005	132	4	From South		From South
E02004952 : Stevenage 009	128	4	From South		From South
E02004912 : North Hertfordshire 004	126	4	S via Graveley		S via Graveley
E02004920 : North Hertfordshire 012	119	3	From west		From west
E02004951 : Stevenage 008	119	3	From South		From South
E02004955 : Stevenage 012	104	3	From South		From South
E02004953 : Stevenage 010	98	3	From South		From South
E02004954 : Stevenage 011	98	3	From South		From South
E02003612 : Central Bedfordshire 014	97	3	From north		via A1
E02003608 : Central Bedfordshire 010	96	3	From north		from north
E02004921 : North Hertfordshire 013	87	2	From west		From west
E02004918 : North Hertfordshire 010	80	2	From west		S via Graveley
E02004919 : North Hertfordshire 011	80	2	From west		S via Graveley
E02004879 : East Hertfordshire 002	77	2	from south		from south

E02003609 : Central Bedfordshire 011	71	2	from north	from north
E02004917 : North Hertfordshire 009	71	2	S via Graveley	S via Graveley
E02004922 : North Hertfordshire 014	71	2	From west	From west
E02004916 : North Hertfordshire 008	65	2	From west	S via Graveley
E02004911 : North Hertfordshire 003	62	2	From west	S via Graveley
E02004914 : North Hertfordshire 006	62	2	From west	S via Graveley
E02003603 : Central Bedfordshire 005	55	2	from north	S via Graveley
E02003611 : Central Bedfordshire 013	55	2	from north west	from north west
E02004923 : North Hertfordshire 015	54	2	From South	From South
E02004915 : North Hertfordshire 007	51	1	From west	From west
E02003604 : Central Bedfordshire 006	46	1	from north	S via Graveley
E02003601 : Central Bedfordshire 003	33	1	S via Graveley	S via Graveley
E02004910 : North Hertfordshire 002	28	1	via A1	S via Graveley
E02003599 : Central Bedfordshire 001	26	1	via A1	via A1
E02003600 : Central Bedfordshire 002	24	1	via A1	via A1
E02004878 : East Hertfordshire 001	24	1	Via A1	S via Graveley
E02004981 : Welwyn Hatfield 002	21	1	From South	from south
E02004909 : North Hertfordshire 001	20	1	S via Graveley	S via Graveley
E02004989 : Welwyn Hatfield 010	20	1	From South	From south
	3,576			

In order to protect against disclosure of personal information, records have been swapped between different geographic areas. Some counts will be affected, particular

WU03EW - Location of usual residence and place of work by method of travel to work (MSOA level)

ONS Crown Copyright Reserved [from Nomis on 25 November 2016]

Population : All usual residents aged 16 and over in employment the week before the census
 Units : Persons
 Date : 2011
 usual residence : E02004944 : Stevenage 001 (2011 super output area - middle layer)

place of work : 2011 super output area - middle layer

MSOA	Count	Method	Count	Method	Count
E02004954 : Stevenage 011	182	13 South	11	South	12
E02004945 : Stevenage 002	176	13 South		0.5 via Back Lane and South	6
E02004951 : Stevenage 008	154	11 South		South	
E02004948 : Stevenage 005	120	9 South		South	
E02004944 : Stevenage 001	56	4 South		South	
E02004983 : Welwyn Hatfield 004	54	4 South		South	
E02004949 : Stevenage 006	48	4 South		South	
E02004989 : Welwyn Hatfield 010	47	3 South		0.5 via Back Lane and South	
E02004914 : North Hertfordshire 006	42	3 North via Graveley		North	
E02004920 : North Hertfordshire 012	39	3 0.5 North Via Graveley		Back Lane and north	
E02004918 : North Hertfordshire 010	29	2 0.5 North Via Graveley		Back Lane and north	
E02004986 : Welwyn Hatfield 007	29	2 South		South	
E02004987 : Welwyn Hatfield 008	28	2 South		South	
E02004913 : North Hertfordshire 005	26	2 North via Graveley		North	
E02004946 : Stevenage 003	24	2 South		South	
E02004981 : Welwyn Hatfield 002	23	2 South		South	
E02004952 : Stevenage 009	22	2 South		South	
E02004894 : East Hertfordshire 017	21	2 South		South	
E02004923 : North Hertfordshire 015	20	1 South		South	
E02004985 : Welwyn Hatfield 006	20	1 South		South	
E02003271 : Luton 014	16	1 South		back Lane and South	
E02004868 : Dacorum 013	16	1 South		South	
E02004916 : North Hertfordshire 008	16	1 North via Graveley		0.5 Back Lane and north	
E02004879 : East Hertfordshire 002	14	1 South		South	
E02004912 : North Hertfordshire 004	14	1 North via Graveley		North	
E02004910 : North Hertfordshire 002	13	1 North via Graveley		North	
E02004950 : Stevenage 007	13	1 South		South	
E02004953 : Stevenage 010	13	1 South		South	
E02004547 : Harlow 004	12	1 South		South	
E02004844 : Broxbourne 002	11	1 South		South	
E02003604 : Central Bedfordshire 006	10	1 west		back Lane and South	
E02003608 : Central Bedfordshire 010	9	1 west		back Lane and South	
E02004889 : East Hertfordshire 012	9	1 south		South	
E02004890 : East Hertfordshire 013	9	1 south		South	
E02004896 : Hertsmeare 001	9	1 south		South	
E02004921 : North Hertfordshire 013	8	1 0.5 North Via Graveley		0.5 via Back Lane and South	
E02004922 : North Hertfordshire 014	8	1 South		0.5 via Back Lane and South	
E02004991 : Welwyn Hatfield 012	8	1 South		0.5 via Back Lane and South	
	1368				

1368

In order to protect against disclosure of personal information, records have been swapped between different geographic areas. Some counts will be affected, particularly small counts at the lowest geographies